

DMS-100 Family

M5316 Meridian Business Set

Description, Installation, Operation, and Maintenance Manual

Release 02.01 Standard February 1999



DMS-100 Family

M5316 Meridian Business Set

Description, Installation, Operation, and Maintenance Manual

NTP: 297-2011-214

Document status: Standard

Version: 02.01

Date: February 1999

© 1999 Northern Telecom

Printed in Canada

NORTHERN TELECOM CONFIDENTIAL: The information contained in this document is the property of Northern Telecom. Except as specifically authorized in writing by Northern Telecom, the holder of this document shall keep the information contained herein confidential and shall protect same in whole or in part from disclosure and dissemination to third parties and use same for evaluation, operation, and maintenance purposes only.

The following are trademarks of Northern Telecom: Nortel, the Nortel globemark, DMS-100, Meridian.

Publication history

October 1996

Release 01.01. Standard version for NA004 and up.

February 1999

Release 02.01. Standard version changed from NA004 and up to CCM04 and up.

Contents

Publication history	iii
Chapter 1: Introduction	1-1
General description	1-1
Physical characteristics	1-2
Other documentation	1-2
Chapter 2: Specifications	2-1
Environmental and safety considerations	2-1
Temperature	2-1
Relative humidity	2-1
Electromagnetic interference	2-1
Atmospheric pollution	2-1
Vibration	2-2
Shock	2-2
Line engineering	2-2
Loop power	2-2
External power	2-2
Chapter 3: Operations and features	3-1
Basic operations	3-1
Acoustics	3-1
Alphanumeric display	3-2
Description of features	3-3
Basic features	3-5
Additional features	3-5
Features operation	3-6
Handsfree operation	3-7
Local features	3-8
C.O. features	3-8
Available features	3-10
Answer back	3-11
Tones	3-11
Switch generated tone characteristics	3-11

Chapter 4: Installation **4-1**

- Installing the M5316 4-1
 - Wall mounting the M5316 4-4
-

Chapter 5: Verification procedures **5-1**

- Verification test routines 5-1
 - Maintenance 5-1
 - Loop check 5-1
 - Polarity check 5-2
 - Station Ringer test 5-3
-

Chapter 6: Replacement parts **6-1**

Figures

- Figure 3-1 M5316 keys and other components 3-3
 - Figure 3-2 M5316 key assignments 3-9
 - Figure 4-1 M5316 bottom view 4-2
 - Figure 4-2 Wall jack/AC adaptor connection 4-3
 - Figure 4-3 M5316 wall mounting locations 4-4
 - Figure 4-4 M5316 base attachment 4-5
 - Figure 4-5 Handset retainer installation 4-6
 - Figure 4-6 Final wall position 4-6
 - Figure 5-1 Feature/line key and LCD assignments 5-7
-

Tables

- Table 3-1 Summary of M5316 keys and indicators 3-4
- Table 3-2 Handsfree features and signals 3-7
- Table 3-3 Switch generated tones 3-12
- Table 6-1 Ordering information 6-1

Chapter 1

Introduction

General description

The M5316 Meridian Business Set is designed for direct connection (through a non-loaded subscriber loop pair) to the Northern Telecom DMS–10, DMS–100, DMS–250, or Meridian SL–100 Digital Switching systems.

The M5316 is partially loop powered and requires the use of a 16 V AC external power supply.

The service provided by the M5316 substitutes low-level signals over a half-duplex, above-voice band (8 kHz) signalling channel for the traditional loop signalling (dial pulse) or inband tone signalling (DTMF tones) on a conventional subscriber loop. In addition to signalling and supervision, messages on the above-voice band signalling channel include signals for implementing the many special features available on the M5316, as well as display characters.

The M5316 offers a choice of selected key and system features—it has 3 fixed keys, a dial pad consisting of 12 fixed keys, 16 programmable feature/directory number keys with LCD indicators (including the two assigned feature keys Handsfree and Mute), and is equipped with a speaker for alerting tones, Handsfree dialing and intercom.

The alphanumeric display module is mounted at the rear top edge of the telephone and is hinged so that the viewing angle can be adjusted physically to reduce glare and maximize the contrast. The maximum display capacity of the display screen is 2 rows of 24 characters each.

Physical characteristics

Figure 3-1 shows the main components of the M5316. The M5316 comes in three different colours:

- Chameleon-grey (Engineering code NT4X42AA)
- BTS light-grey (Engineering code NT4X42BA)
- Black (Engineering code NT4X42CA)

The Mean Time Between Failure (MTBF) for the M5316 is at least 100 years.

Other documentation

Other information pertaining to Meridian Business Sets can be found in the following documents:

297-2001-100	Integrated Business Network (IBN) —Description
297-1001-114	Operational Measurements (OM)
297-1001-250	Testing and Acceptance for Initial Installation
297-1001-310	Table Editors User Guide
297-1001-518	Operational Measurements—Man-Machine Interface
297-2011-180	DMS-100 Business Set—Line Engineering Rules
P0749051	M5316 MBS User Guide (English/French)
P0800729	M5316 MBS User Guide (Spanish)

Chapter 2

Specifications

The following specifications govern the performance of the M5316 Business Set and the environmental conditions under which this performance is achieved.

Environmental and safety considerations

The M5316 meets the Canadian and U.S. mandatory interconnect requirements for Telephone Equipment, CSA, DOC, UL, FCC (part 15 & part 68).

Temperature

In the *Operating State*, the M5316 temperature range is 0 °C to 50 °C (32 °F to 122 °F).

In the *Non-Operating State*, the M5316 temperature range is -20 °C to 70 °C (-6 °F to 158 °F).

Relative humidity

20% to 95% (non-condensing). At temperatures above 34 °C (93 °F), relative humidity is limited to 52mbar of water vapour pressure.

Electromagnetic interference

The radiated and conducted electromagnetic interference meets the requirements of Subpart J of Part 15 of the FCC rules for class B computing devices.

Atmospheric pollution

The M5316 is designed to withstand normal atmospheric conditions throughout its life and during shipment and storage as defined in the International Electromechanical Commission (IEC) document 50 (salt, mist, atmospheric dust, sulfur dioxide, and hydrogen sulfide exposure).

Vibration

The M5316 is designed to work to specifications after being subjected to the following vibrations in each of three orthogonal directions for 90 minutes:

- Vibration frequency of 5 Hz to 500 Hz
- Maximum half displacement 0.35mm (0.014 in)
- Maximum acceleration 1.5m/s/s.

Shock

When *packaged*, the M5316 is designed to withstand normal handling during shipment.

When *unpacked*, the M5316 is designed to withstand accidental dropping during normal use, without sustaining damage, as specified below:

- Telephone: when dropped on any face or corner from a height not exceeding 0.75m (30in)
- Handset: when dropped from a height not exceeding 1.5m (60in)

Line engineering

The M5316 operates to its full potential through twisted pair wiring on transmission lines selected by the rules provided in NTP 297–2011–180.

The M5316 interfaces with the business set (6X21AC) line card in the Line Concentrating Module (LCM) of the DMS–10/DMS–100/Meridian SL-100 Central Office (CO) equipment. The 6X21AC supports one business set per line card.

Loop power

The M5316 is partially loop powered by a balanced 440 Ohm battery feed from the switching equipment. The switch battery voltage supplied to the loop is nominally 52 VDC with a minimum of 42.75 VDC and a maximum of 56 VDC. Under normal conditions the polarity must be negative on the Ring lead with respect to the Tip lead.

The current drawn from the loop is 16 ± 1 mA when the set is active. The current drawn from the loop is 10 ± 1 mA when the set is inactive.

External power

The M5316 requires a 16 V AC external power supply rated at 375 mA. During a power failure, the Handsfree and RT clock functions are not available.

Chapter 3

Operations and features

Basic operations

The M5316 Meridian Business Set can be used to make voice calls and operate selected DMS-10, DMS-100, or Meridian SL-100 features. All supported features can be accessed using keys provided on the M5316. For further details about software requirements, refer to NTP 297-2011-100 and NTP 297-1001-310 respectively. Dial pad, DN, and feature key layout is shown in Figure 3-1.

Note that the M5316 must not be assigned as a maintenance set.

Before attempting to operate the M5316, please refer to the *M5316 Meridian Business Set User Guide*. This document is shipped with the set and contains instructions for making calls and how to use various features.

Acoustics

A speaker is used for alerting tones, call monitoring (on-hook dialing), Handsfree dialing, and intercom.

Alphanumeric display

The M5316 display screen allows access to the following features:

Called Number Display/Called Name Display

The display of the called number (or name of the party being called, when available) is always activated as dialing takes place.

Calling Number Display/Calling Name Display

The calling number (or name of the calling party, when available) for calls originating within the same switch is displayed when the first ringing tone sounds for an incoming call at the Prime DN. If the incoming call terminates at a secondary DN, the number is displayed only after lifting the receiver.

Query Time and Date

One of the feature keys must be assigned for accessing the QTD display. That key should be labelled Time/Date for easy identification.

Feature programming and usage

The display screen shows important information and prompts when using or programming M5316 features.

Description of features

The M5316 Business Set (see Figure 3-1) is characterized by the following:

- there are 15 fixed keys with no LCD indicators: Release key (1), Hold Key (1), Volume key (1), dial pad keys (12)
- there are two fixed keys with LCD indicators (Handsfree and Mute)
- there 14 assignable key/LCD indicator pairs.

The operation of these keys and other components is summarized in Table 3-1.

Figure 3-1
M5316 keys and other components

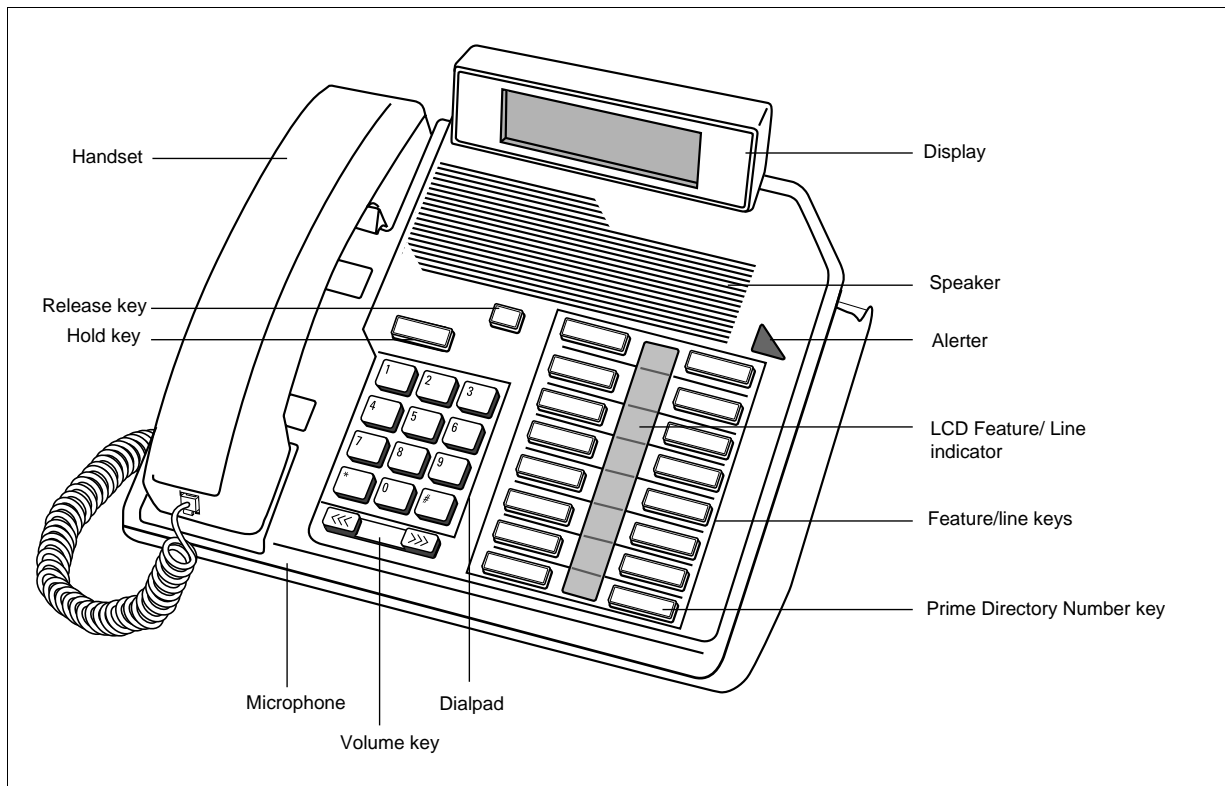

Table 3-1
Summary of M5316 keys and indicators

Key or indicator	Description
Speaker	Monitors the progress of a call without lifting the handset.
Handset	Used for talking on the phone—automatically selects the prime directory number when lifted.
Display	Shows call and installation information.
Alerter	Flashes to indicate incoming calls.
Dial pad	Used for entering numbers and the <input type="text" value="#"/> or <input type="text" value="*"/> keys.
Volume key	Adjusts the volume of the ring and the speaker.
<input type="text" value="Ris"/>	Releases a call without replacing the handset.
<input type="text" value="Hold"/>	Puts a call on hold.
<input type="text" value="Handsfree"/>	See "Handsfree Operation".
<input type="text" value="Mute"/>	See "Handsfree Operation".
14 feature/line keys	Acts as line key or as a feature key depending upon how the set is programmed.
LCD indicators	Indicates the status of the feature/line keys:
No half diamond (Off)	Feature or line is not active.
Steady half diamond (On)	Feature or line is active.
Slow flashing half diamond (60IPM)	Line is ringing or feature is being programmed.
Fast Flashing half diamond (120IPM)	Line is on hold .

Basic features

Every Business Set has the basic features described below.

Automatic Prime Directory Number (PDN) selection

Allows the user to select the prime DN (i.e. the DN assigned to the first feature/line key) by going off-hook to answer a call without pressing a DN key.

On-hook dialing

Allows the user to select a line and dial the call without lifting the handset. Once the party answers, the handset must be lifted to speak.

Listen on hold

Activated by pressing the Hold key (associated LCD flashes), placing the handset back in its cradle, and re-selecting the line to be monitored (associated LCD on).

Alerting tones

Warble tone sounds when the telephone is on-hook, 500 Hz local buzzer tone sounds when the telephone is off-hook and the associated LCD indicator flashes.

Additional features

In addition to the basic features, the M5316 provides the following features:

LCD Screen

Two rows of 24 alphanumeric characters can be displayed.

Handsfree calling

Allows the user to carry on a telephone conversation without lifting the handset (applies to both the originating and answering a call).

Microphone muting

Allows the user to listen to a call without the other party being able to hear any sound from the user.

Automatic Answer Back (AAB)

This is an optional feature which can be provided with or without a dedicated feature key. When installed, AAB allows an incoming call to the PDN to be answered automatically after one ring. Conversation takes place through the integrated handsfree functions without manually controlling the telephone.

Features operation

The fixed keys on the M5316 Business Set provide these permanent functions:

- dialing
- call Hold
- call Release
- Volume control

Dial pad

Before a call is established, no tone-feedback is provided when the dialing keys are being pressed. After a call has been established, end-to-end signalling using CO generated DTMF tones is enabled.

Hold

The Hold function has two modes of operation—manual and automatic. With the user engaged in a call, the call can be put on hold either by pressing the  key or by pressing another DN key. In either case, the DN LCD changes from ON to *winking* and the user is free to answer or make another call.

Release

The  (Release) key performs a similar function as going on-hook (i.e. when pressed, it terminates a call). The DN LCD associated with the released call changes from ON to OFF, but the status of the Set remains off-hook to the switch.

Volume control

The loudness of any sound which comes through the speaker (i.e. ringing, dial tone, busy tone and on-hook monitoring) is controlled by one key with two toggle positions. Tapping the key at the right hand side increases the volume while tapping it at the left-hand side decreases it. Each time the key is pressed, the volume level changes one step, as shown on the volume bar display (there are seven volume levels).

The volume for ringing tones can only be adjusted while alerting is in progress and is automatically stored at the new level. The on-hook monitor volume level can be adjusted and automatically stored while monitoring. Volume levels can also be pre-set to a new level in program mode.



If the M5316 Business Set is disconnected from the line and then reconnected, all volume settings return to the original factory default values

(Mid-point setting for alerting tones and minimum setting for on-hook monitoring).

Handsfree operation

There are two permanently assigned keys with associated LCD indicator triangles which enable Handsfree conversation (HANDSFREE) and microphone muting (MUTE). Refer to the following table for a list of Handsfree features and signals:

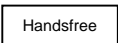
Table 3-2
Handsfree features and signals

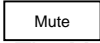
State	Action	Result and verification
Incoming call on PDN	Press 	Set goes off-hook and Handsfree is enabled. Prime DN and Handsfree LCD indicators are ON and the microphone and speaker are enabled.
Handsfree ON	Press 	Call is terminated. Set goes on-hook and Handsfree is disabled. Handsfree LCD indicator goes OFF and the microphone and speaker are disabled.
Handsfree ON	Lift handset	Transfers speech to the handset. Handsfree indicator goes OFF.
Handsfree ON	Press 	Disables microphone but speaker remains on. Press  again to restore microphone. The Mute LCD indicator winks during microphone use; winking stops once Mute key is pressed again. The Mute feature also functions in handset mode to disable the mouthpiece.

Local features

The M5316 has the following local features which can be set up to make it easier to use and to customize the set to meet specific user requirements. The Program key allows access to Programming mode to set up the following features:

- Alerter Volume
- Time and Date Set
- Time and Date Format
- Call Timer
- Display Language
- C.O. Features
- Predial
- Memory Number

Note that an incoming call interrupts the activation or programming of all local functions. Local features are also not available during an active call, with a call on hold, or when a C.O. feature is active (the Time/Date C.O. feature is active for 12 seconds).

C.O. features

Using the C.O. features local function, the M5316 can be programmed to enable or disable the following three additional feature keys:

- Save Number
- Memory Number
- Pause

Note that the M5316 is initially set up to have the Save Number, Memory Number, and Pause keys available to you and they appear at the feature key locations shown in Figure 3-2.

Figure 3-2
M5316 key assignments

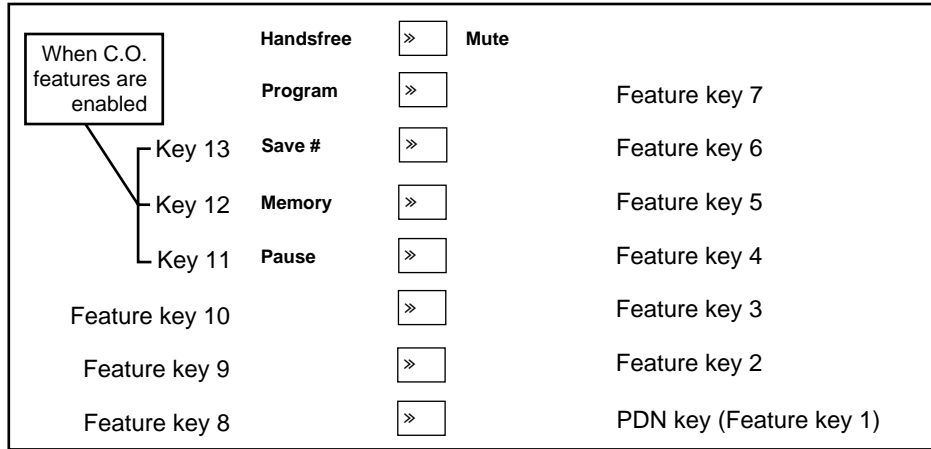

When C.O. features are enabled, these key locations are dedicated to provisioned switch features instead of the Save Number, Memory Number, and Pause features.

Refer to the *M5316 User Guide* for more information about the operation of local features.

Available features

Feature key 1 is always assigned to the Prime Directory Number (PDN). If more than one Directory Number (DN) is available, additional feature keys can be assigned to these DNs progressing from feature key 1 to feature key 2 and so on. Any remaining feature keys can be assigned a subset of a number of features. Examples of some of the available features are given as follows:

- Auto Answer Back(AAB)
- Automatic Dial (AUD)
- Automatic Line (AUL)
- Busy Override (EBO)
- Call Forward (CF)
- Call Park (PARK)
- Call Pickup (CPU)
- Call Transfer (CXR)
- Call Waiting (CWT)
- Directed Call Park (DCP)
- Directory Numbers (DN)
- Group Intercom (GIC)
- Individual Business Line
- Intercom (ICM)
- Make Set Busy (MSB)
- Malicious Call Hold (MCH)
- Message Waiting (MWT)
- Multiple Appearance Directory Numbers (MADN)
- Privacy Release
- Ring Again (RAG)
- Set Busy Indicator (SBI)
- Speed Calling (SCS, SCL, or SCI)
- 3-way Calling/Call Transfer (TWC/CXR)
- 6-port Conference (CONF 6)

Answer back

Auto Answer Back (AAB) can be provided on the M5316 as an assigned feature or as a key-accessible feature. As an assigned feature, it is always operational. As a key-accessible feature, AAB allows the user to activate or deactivate the AAB feature as required. If AAB is activated, an incoming call to the PDN is automatically answered after a two-second burst of alerting tone. Conversation can start in Handsfree mode using the speaker and microphone. Microphone muting is possible with AAB mode. When the user lifts the handset to speak, speech is shifted to the handset. The call is disconnected when the calling party hangs up, but the Handsfree LCD indicator remains ON until either the Release key is pressed or the handset is lifted from and then returned to the cradle.

Tones

A speaker is used for alerting tones and call monitoring (on-hook dialing and listen on hold). A locally generated buzzer (500 Hz) tone is utilized for call waiting and off-hook alerting. All other telephony tones are provided by switching equipment from a Tone Card.

Switch generated tone characteristics

The various tones heard on the M5316 are defined in Table 3-3.

Table 3-3
Switch generated tones

Tone	Characteristic
Ringling	Interrupted warble tone, typically 2 seconds on, 4 seconds off.
Busy	Interrupted tone, 1 second on, 1 second off.
Call Waiting	Short burst of buzzer (500 Hz), 10 second intervals.
Confirmation	Three short bursts of tone, not repeated. This tone informs the user that the feature requested has been implemented. This tone is present only when the feature access code is dialed.
Dial	Continuous tone consisting of 2 frequencies.
Reorder	Interrupted tone, 1/2 second on, 1/2 second off. This tone informs the user of unavailable feature, all trunks busy, illegal code, etc.
Ring Again	Sort burst of buzzer tone (500 Hz) once only to inform the user that the previously busy station opt trunk line is now free.
Special Dial	Three short bursts of dial tone, followed by a continuous dial tone. This tone informs the user that the dialed features (e.g. call forwarding) has been activated and further digits can now be dialed.

Chapter 4

Installation

Installing the M5316

Before installing the M5316, check the package contents and cables, as described below. To install the M5316, follow Procedure 4-1. If the M5316 needs to be mounted on the wall, follow Procedure 4-2.

Unpacking or packing

Use proper care while unpacking any M5316 set. Check for damaged containers so that appropriate claims can be made to the transport company for items damaged in transit.

If a telephone must be returned to the factory, make sure it is packed in its original container to avoid damage during transit. Remember to include all loose parts in the shipment (e.g. cords and handset).

Cables



CAUTION

Polarity sensitivity

Cable connections for the M5316 are polarity sensitive. A polarity reversal will cause the set to fail.

Installation requires you to plug in cords to the Teladapt jacks that are accessible in the base of the telephone. Cord restraining tabs are provided for security. Make the necessary connections to the Teladapt connecting block (Tip [+] green lead and Ring [-] red lead), and plug the line cord into the Teladapt jack. Continue with the installation instructions provided on the following page.

The required jack is an RJ11 c/w.

Procedure 4-1
How to install the M5316

Step	Action
1	Place the telephone in the work area (close to line cord connecting block/wall jack) upside down on soft, solid, and level work surface to prevent damage to movable keys and the telephone face.
2	Connect one end of the handset cord into the 4-conductor Teladapt connection in the base of the handset. Connect the other end of the handset cord into the handset jack in base of the M5316 (labelled E in Figure 4-1) . The Teladapt connectors have a latch-tab which ensures correct alignment and prevents the cord from being pulled out inadvertently during service. Make sure that this latch is firmly snapped into place.

Figure 4-1
M5316 bottom view

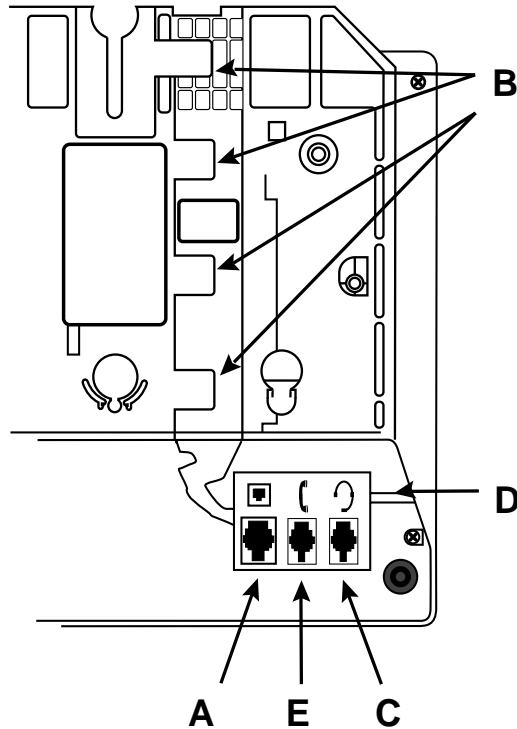

3 Route the handset cord through the channel provided (**D** in Figure 4-1).

—continued—

Procedure 4-1
How to install the M5316 (continued)

Step	Action
4	Connect the line cord to the connector in the base (A in Figure 4-1) and push it under the restraining tabs (B) in the line cord channel of the telephone base.
5	Turn the telephone right side up and place it into its final position.
6	Remove the number lens by inserting a paper clip end into the hole at the side and pop off the plastic lens. Print the directory number on the designation card and insert it into the lens recess. Snap the plastic lens back into place.
7	Designate button labels for key designations.
8	Fold the labels, insert them into the plastic button covers, and snap each button cover over the appropriate feature/line key. Press down on each key until the button cover fits in place.
9	Insert the other end of the line cord into the open jack (A in Figure 4-2) on the plastic "pigtail" connector (B). Make sure it has been securely snapped into place. Insert the free end of the "pigtail" cord (C) into the wall jack (D). Note that you should never remove the pigtail cord

Figure 4-2
Wall jack/AC adaptor connection

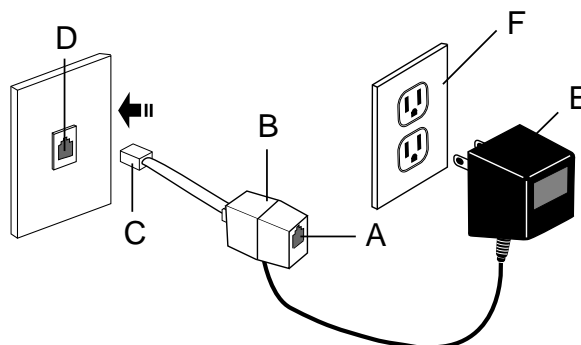

- 10 Plug in the AC adaptor (**E** in Figure 4-2) into a AC 120V wall socket (**F**). Wait a minimum of 20 seconds to allow for proper power-up before using the Meridian Business Set. This completes the installation. If the set must be prepared for mounting on a wall, follow Procedure 4-2 .

—end—

Wall mounting the M5316

Your telephone set has been prepared at the factory for use on your desk. If you require the set to be positioned on a wall, follow procedure 4-2.

Procedure 4-2

How to mount the M5316 on the wall

Step	Action
1	<p>Turn the telephone set upside down and locate the two screws (A in Figure 4-3) in the wedge-shaped base as shown . Remove the screws from the base and set them aside.</p> <p>Note: If the M5316 is attached to an M522 Add-On unit, the base is longer than shown in Figure 4-3 and there is an additional screw to remove.</p>

Figure 4-3
M5316 wall mounting locations

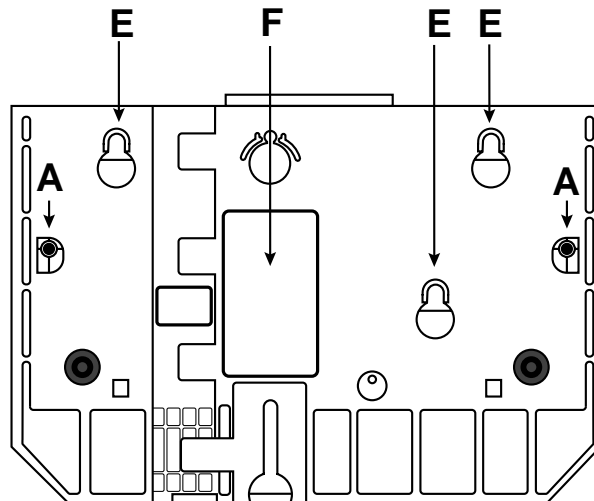

2	Pull off the wedge-shaped base from the telephone set.
3	If the set is to be connected to a line cord connecting block mounted on the wall, push out the knock-out section in the base (F) as shown in Figure 4-3.

—continued—

Procedure 4-2
How to mount the M5316 on the wall (continued)

Step	Action
4	Reposition the wedge-shaped base (B in Figure 4-4). Press the base firmly into the bottom of the set until the plastic tabs have clicked into place.

Figure 4-4
M5316 base attachment

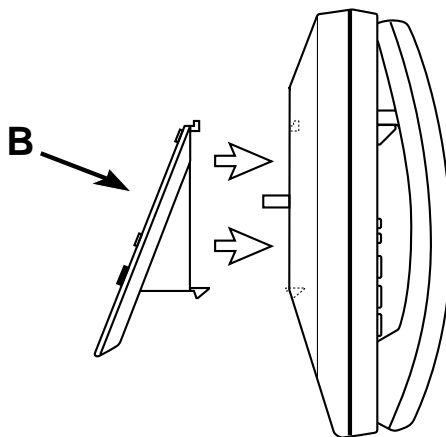

5	Reinsert the two screws into the screw mounts shown in Figure 4-3. Tighten the screws until the wedge-shaped base is seated securely into the bottom of the set. Do not over tighten the screws as this may cause the plastic to crack.
---	---

—continued—

Procedure 4-2
How to mount the M5316 on the wall (continued)

Step	Action
6	Position the handset retainer (C in Figure 4-5) into the handset cradle. The handset retainer is included in the small package of plastic key caps which accompanies your telephone set. Insert the two plastic tabs (D) on the retainer into the two holes provided. Press firmly until the retainer clicks into place.

Figure 4-5
Handset retainer installation

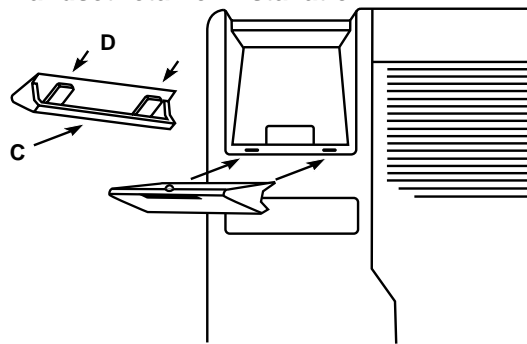

7	Attach the telephone set to a standard wall bracket using the mounting holes (E in Figure 4-3) provided on the wedge-shaped base. Once mounted on the wall bracket, the telephone set should hang flush to the wall, as shown in Figure 4-6. Note that the knock-out section removed in step 3 allows enough space to accommodate the line cord connecting block, if present.
---	---

Figure 4-6
Final wall position

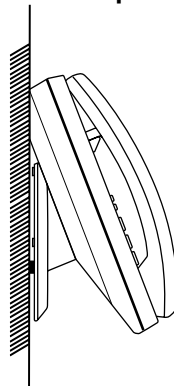

—end—

Chapter 5

Verification procedures

Verification test routines

This chapter describes M5316 maintenance and the following acceptance tests:

- Loop check
- Polarity check
- Station Ringer test

If the criteria outlined in the *Line Engineering Rules*, NTP 297–2011–180, are observed, impulse or background noise and crosstalk compatibility problems are unlikely to occur.

Before attempting to establish a communication path to another telephone and to verify the enabled features, perform the loop check and check the Tip/Ring polarity.

Maintenance

Maintenance of the Meridian Business Set is limited to replacement of the set and/or other field replaceable items as itemized in Chapter 6 “Replacement Parts”.

Loop check

Loop and linecard tests must be performed at the switching equipment (refer to NTP 297–2011–180). It is assumed that loops and linecards have been checked prior to the installation of any business sets.

Verify that the loop resistance is ≤ 1230 Ohm and that the loop loss is ≤ 24 dB at 8 kHz.

Polarity check

The M5316 is polarity sensitive. If problems arise when the set is to be put into service, follow Procedure 5-1.

Procedure 5-1

How to verify the polarity

Step	Action
1	If the set does not respond (no dial tone) after 20 seconds, check polarity of the tip and ring leads (tip +, ring –).
2	If the tip and ring lead reversal does not solve the problem, restore tip and ring to original polarity and change the set.

Station Ringer test

The Station Ringer test (SRT) tests the hardware of the M5316 Business Set and can be performed by the installer or repairman at the site with no involvement of Central Office personnel.

No incoming calls can be received for the duration of a Station Ringer test. In order to prevent prolonged line blockages, this test is limited to a 7 minute interval after which the line is automatically restored to normal and the test terminated.

When testing the dial pad, a corresponding digit is displayed (echoed) on the lower line of the display screen each time a key is pressed. If more than 23 digits are pressed, the displayed digits scroll onto the upper line of the display.

If the M5316 is equipped with a M522 add-on module(s), the LCDs on the add-on modules are not cleared until step 42. Also, Handsfree and Mute LCDs are not turned on or off except in step 36

Once the test has terminated, the system does not attempt to restore any LCD to its pre-test state. The LCDs are OFF at the end of the test, with features in the same state as before the test. A background audit restores all feature indicators at its next occurrence (audit intervals are switch and load related). Any newly activated features after termination of the test procedure are indicated normally.

Use Procedure 5-2 to conduct the test. The action to follow, the key to press, or the switch to operate is shown in the *Action or key/switch operated* column. The response must be as described in the *Response* column. LCD and key numbering are shown in Figure 3-2 (note that Key and LCD designations are for testing purposes and are not marked on the keys or LCD windows). The column *Message* indicates the messages generated to produce the correct response.

Before starting the SRT

1. Enable C.O. features using program mode.
2. Disable all local features (e.g. Call Timer, Pre-dial).

Procedure 5-2**How to perform the Station Ringer test**

Step	Action or key/switch operated	Response	Messages
1	Handset ON-hook. Press PDN key and dial STR (access code) using on-hook dialing.	All LCD's ON	LCD indicator ON
	Note: All LCD indicators should be off before you start the test. The 3–14 digit access code consists of a one to seven digit number (which is assigned by the telephone company according to local preferences) followed by the last two to seven digits of the PDN assigned to the telephone to be tested. In North America, the access code usually consists of the number 57, followed by the last five digits of the PDN. If the required digits are dialed incorrectly, a Reorder tone sounds which makes it necessary to press the Release key and start again. If all digits are correct, all LCD indicators on the set light up.		
2	Handset OFF-HOOK	All LCDs FLASH	LCD indicator FLASH
3	Handset ON-HOOK	All LCDs WINK	LCD indicator WINK
4	Handset OFF-HOOK	All LCDs ON	LCD indicator ON
5	Handset ON-HOOK	All LCDs OFF	LCD indicator OFF
6	Dial Pad key 1	LCD 1 ON	Soft Reset, LCD ON
7	Dial Pad key 2	LCD 2 ON	Soft Reset, LCD ON
8	Dial Pad key 3	LCD 3 ON	Soft Reset, LCD ON
9	Dial Pad key 4	LCD 4 ON	Soft Reset, LCD ON
10	Dial Pad key 5	LCD 5 ON	Soft Reset, LCD ON
11	Dial Pad key 6	LCD 6 ON	Soft Reset, LCD ON
12	Dial Pad key 7	LCD 7 ON	Soft Reset, LCD ON
13	Dial Pad key 8	LCD 8 ON	Soft Reset, LCD ON
14	Dial Pad key 9	LCD 1 & 8 ON	Soft Reset, LCD ON
15	Dial Pad key 0	LCD 2 & 8 ON	Soft Reset, LCD ON
16	Dial Pad key •	All LCDs ON	Soft Reset, LCD ON
17	Dial Pad key £	All LCDs 1 OFF	Soft Reset, LCD ON
18	Feature key 1	LCD 1 ON	Soft Reset, LCD ON
19	Feature key 2	LCD 2 ON	Soft Reset, LCD ON
20	Feature key 3	LCD 3 ON	Soft Reset, LCD ON
21	Feature key 4	LCD 4 ON	Soft Reset, LCD ON

—continued—

Procedure 5-2
How to perform the Station Ringer Test (continued)

Step	Action or key/switch operated	Response	Messages
22	Feature key 5	LCD 5 ON	Soft Reset, LCD ON
23	Feature key 6	LCD 6 ON	Soft Reset, LCD ON
24	Feature key 7	LCD 7 ON	Soft Reset, LCD ON
25	Feature key 8	LCD 8 ON	Soft Reset, LCD ON
26	Feature key 9	LCD 9 ON	Soft Reset, LCD ON
27	Feature key 10	LCD 10 ON	Soft Reset, LCD ON
28	Feature key 11	LCD 11 ON	Soft Reset, LCD ON
29	Feature key 12	LCD 12 ON	Soft Reset, LCD ON
30	Feature key 13	LCD 13 ON	Soft Reset, LCD ON
31	RELEASE key	LCD 2 & 8 ON	Soft Reset, LCD ON
32	HOLD key	Dial tone, LCDs 1 –5 ON	Soft Reset. Turn on TIP/Ring to Speaker. LCD ON
33	Vol UP	Volume up	None (Test Voice Volume control)
34	Vol DOWN	Volume down	None (Test Voice Volume control)
35	Handset OFF-HOOK	Dial tone switches to Handsfree speaker. All LCDs WINK with the exception of the Handsfree indicator which is ON.	Turn on TIP/Ring to Speaker. Turn off Handset. LCD WINK.
36	Handset ON-HOOK	Dial tone switches to Handsfree speaker. All LCDs WINK.	Turn on TIP/Ring to Speaker. Turn off Handset. LCD WINK.
37	HOLD key	1 second buzz (500 Hz). LCDs 6–14 ON.	Turn On/Off Alert B, LCD ON.
38	HOLD key	Ringing. All LCDs OFF.	None (Ring tone from CO).
39	Vol UP	Volume up	None (Test Ring Volume control).

—continued—

Procedure 5-2**How to perform the Station Ringer Test (continued)**

Step	Action or key/switch operated	Response	Messages
40	Vol DOWN	Volume down	None (Test Ring Volume control).
41	HOLD key	LCD 1–13 and Program LCD are ON. 10/10 is shown on the LCD display.	Soft reset
<p>Note: When the Hold key is pressed, the LCD indicators for keys 2,3, and 4 flash for approximately 2–4 seconds. This indicates that a circuit test is running. No keys can be operated during this time as this may cause test failure. When the circuit test is completed, 10/10 is displayed in the display screen in most cases. The numbers depend upon the CO parameter table and may vary from 10 to 50; however, the number to the left of the slash should equal the number to the right. If the indications are as described above, the test has passed. A test failure is indicated when the following occurs:</p> <ul style="list-style-type: none"> • the two numbers are not equal • only the LCD indicators for keys 1, 2, and 8 are ON • LCD indicators for keys 1, 2, and 8 wink (press the Hold key again to repeat the SRT. 			
42	HOLD key	Display is cleared	Hard reset
43	Press PROGRAM key twice	Program LCD is cleared.	Local function

—end—

Chapter 6

Replacement parts

The M5316 has few field replaceable parts. The handset, handset cord, line cord equipped with Teladapt connectors, key lenses and labels can be changed. If a Business Set fails to function properly, or if mechanical breakage occurs, do not attempt to effect repairs in the field. Return the unit to the manufacturer using the original packing materials.

Table 6-1
Ordering information

Description	Ordering code	Engineering code
Meridian M5316 Basic Business Set, Chameleon-grey, made in Australia	B0240405	NT4X42AA
Meridian M5316 Basic Business Set, BTS light grey, made in Australia	B0240406	NT4X42BA
Meridian M5316 Basic Business Set, Black, made in Australia	B0240407	NT4X42CA
Meridian M5316 Basic Business Set, Chameleon-grey, made in Canada (Brocktel)	B0246074	NT4X42KA
Meridian M5316 Basic Business Set, BTS light-grey, made in Canada (Brocktel)	B0246075	NT4X42LB
Meridian M5316 Basic Business Set, Black, made in Canada (Brocktel)	B0246076	NT4X42MC
Meridian M5316 Basic Business Set, Chameleon-grey, made in Australia (OZ OPTUS)	B0242910	NT4X42DA
Meridian M5316 Basic Business Set, BTS light grey, made in Australia (OZ OPTUS)	B0242911	NT4X42EA
Meridian M5316 Basic Business Set, Black, made in Australia (OZ OPTUS)	B0242912	NT4X42FA
—continued—		

Table 6-1
Ordering information (continued)

Description	Ordering code	Engineering code
Meridian M5316 Basic Business Set, Chameleon grey, made in Australia (OZ TELSTRA)	B0242925	NT4X42GA
Meridian M5316 Basic Business Set, BTS light grey, made in Australia (OZ TELSTRA)	B0242926	NT4X42HA
Meridian M5316 Basic Business Set, Black, made in Australia (OZ TELSTRA)	B0242927	NT4X42JA
Card, Key Button Labels (English/French)	P0749551	P0749551
Card, Key Button Labels (Spanish)	P0744292	P0744292
M5316 Documentation package	B0240551	NT4X4260
M5316 Documentation package (OZ OPTUS)	B0242935	NT4X4270
M5316 Documentation package (OZ TELSTRA)	B0242940	NT4X4280
Handset assembly (Chameleon grey) for NT4X42AA	A0358849	NT0C09EE-35
Handset assembly (BTS light- grey) for NT4X42BA	A0358850	NT0C09EE-93
Handset assembly (Black) for NT4X42CA	A0388557	NT0C09EE-03
Handset cord, 2.5m (8 ft) long (Chameleon grey) for NT4X42AA	A0327131	NE-H4DUQC-35
Handset cord, 2.5m (8 ft) long (BTS light-grey) for NT4X42BA	A0327132	NE-H4DUQC-93
Handset cord, 2.5m (8 ft) long (Black) for NT4X42CA	A0327133	NE-H4DUQC-03
M5316 Base, Chameleon grey	P1013635	
M5316 Base, BTS light-grey	P1013693	
M5316 Base, Black	P1013603	
M5316/M5216 Cover, Chameleon grey	P1013735	
M5316/M5216 Cover, BTS light-grey	P1013793	
M5316/M5216 Cover, Black	P1013703	
AC Power Adaptor	B0230393	NPS50220-08L6
Key cap set	B0240555	NT4X4261
Line cord, silver-grey, 1.84 m (6 ft) long	A0346862	NPS50318-04L02
—end—		

DMS-100 Family

M5316 Meridian Business Set

Description, Installation, Operation, and
Maintenance Manual

© 1999 Northern Telecom

NORTHERN TELECOM CONFIDENTIAL: The information contained in this document is the property of Northern Telecom. Except as specifically authorized in writing by Northern Telecom, the holder of this document shall keep the information contained herein confidential and shall protect same in whole or in part from disclosure and dissemination to third parties and use same for evaluation, operation, and maintenance purposes only.

Nortel, the Nortel globemark, DMS-100, Meridian are trademarks of Northern Telecom.

Information is subject to change without notice. Northern Telecom reserves the right to make changes in design or components as progress in engineering or manufacturing may warrant.

NTP: 297-2011-214
Document status: Standard
Version: 02.01
Date: February 1999
Printed in Canada

NORTEL
NETWORKS™