

297-0301-301

DMS-100 Family

Cutover Conversion Services

Customer Grooming Method of Procedure

BCS27 and up unless reissued Standard 02.05 July 1992

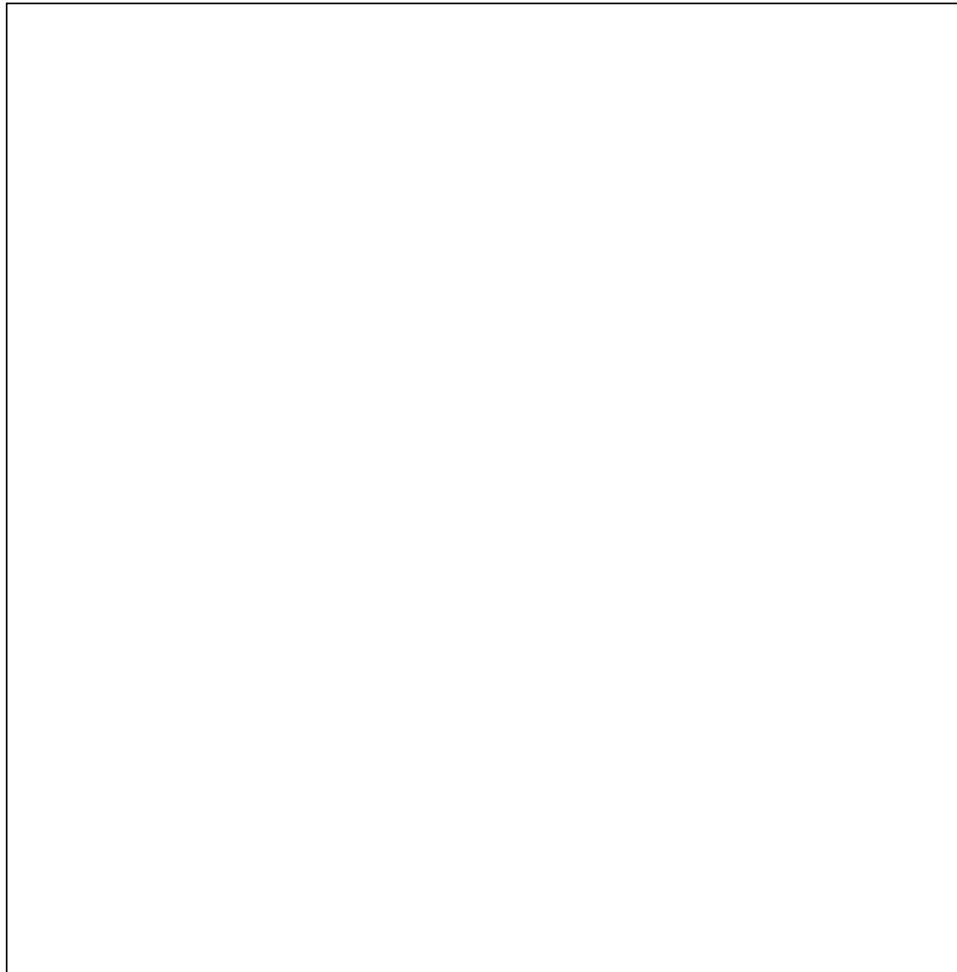

DMS-100 Family

Cutover Conversion Services

Customer Grooming Method of Procedure

Publication number: 297-0301-301
Product release: BCS27 and up unless reissued
Document release: Standard 02.05
Date: July 1992

© 1989, 1990, 1991, 1992 Northern Telecom
All rights reserved.

Printed in Canada and printed in the United States of America.

Information is subject to change without notice. Northern Telecom reserves the right to make changes in design or components as progress in engineering and manufacturing may warrant.

DMS, DMS SuperNode, MAP, Digitone and NT are trademarks of Northern Telecom. 1AESS, 1ESS, 2ESS, 2BESS, 3ESS, ESS, SLC96 and TouchTone are trademarks of AT&T.

Publication history

July 1992

BCS34 Standard 02.05 provides enhancements to the detail of steps in the grooming sequence of activities.

October 1991

BCS33 Standard 02.04 half-tapping for modular type frames added.

March 1991

BCS32 Standard

- Release 02.03 corrected document number version and issue.
- Release 02.02 converted document to Interleaf authoring format.

Revision bars in the table of contents identify the sections where technical information has been changed. Revision bars in the outside margin of a page indicate text that has been added or revised.

Contents

About this document	v
When to use this document	v
How Cutover Conversion Services documentation is organized	v
Introduction	1-1
Half-tapping	1-1
Grooming	1-5
Grooming analysis methods	1-6
Grooming analysis reports	1-9
Method of procedure	2-1
General	2-1
Providing TDA-format data from ESS switch to CCS	2-1
Specifying concentrators to skip for concentrator-LSG mapping	2-2
Assigning circuit packs to classes of service	2-3
Resolving circuit pack conflicts (grooming)	2-5
Interpreting the grooming analysis reports	3-1
Circuit pack summary report	3-1
Frame analysis - OE range information	3-5
Frame analysis - concentrators with no assigned DNs	3-7
Concentrator - LSG mapping	3-7
Unique classes of service	3-10
Unique classes of service with card codes	3-12
LCCs without working DN assignments	3-14
Test lines with a DN assigned	3-16
Circuit pack conflicts - ESS impacting	3-18
Circuit pack conflicts - DMS impacting	3-21
Spare or unequipped OEs - unavailable	3-23
Spare or unequipped OEs - available	3-23
OEs with multiple DNs assigned	3-25
Allowed circuit pack conflicts	3-27
Circuit pack usage summary	3-29
List of terms	4-1
List of figures	
Figure 1-1	ESS OE-to-DMS LEN relationships for half-tapping (COSMIC-type, conventional frame) 1-3

Figure 1-2	ESS OE-to-DMS LEN relationships for half-tapping (modular frame) 1-4
Figure 1-3	1:1 line assignment methodology 1-5
Figure 1-4	Grooming sequence of activities 1-7
Figure 2-1	Assigning circuit packs to classes of service 2-4
Figure 3-1	Circuit pack summary report (without LNINV) 3-2
Figure 3-2	Circuit pack summary report (withLNINV) 3-3
Figure 3-2	Circuit pack summary report (with LNINV) (continued) 3-4
Figure 3-3	ESS OE and DMS LEN numbers 3-5
Figure 3-4	Frame analysis - OE range information 3-6
Figure 3-5	Frame analysis - concentrators with no assigned working DNs 3-7
Figure 3-6	Concentrator - LSG Mapping 3-9
Figure 3-7	Unique classes of service 3-11
Figure 3-8	Unique classes of service with card codes 3-13
Figure 3-9	LCCs without working DN assignments 3-15
Figure 3-10	Test lines with a DN assigned 3-17
Figure 3-11	Circuit pack conflicts - ESS impacting 3-20
Figure 3-12	Circuit pack conflicts - DMS impacting 3-22
Figure 3-13	Spare or unequipped OEs - unavailable 3-23
Figure 3-14	Spare or unequipped OEs - available 3-24
Figure 3-15	OEs with multiple DNs assigned 3-26
Figure 3-16	Allowed circuit pack conflicts 3-28
Figure 3-17	Circuit pack usage summary 3-30

List of procedures

Procedure 2-1	Providing TDA-format data to CCS 2-2
Procedure 2-2	Confirming/indicating concentrators/LSGs to skip 2-3
Procedure 2-3	Procedure title 2-5

About this document

Cutover conversion services support office applications replacing AT&T Electronic Switching System (ESS) type 1, 1A, 2, 2B, or 3 with DMS-100 central office switching equipment. This document describes how Northern Telecom performs the switch grooming analysis, provides details to the operating company using data contained in grooming analysis reports, and discusses the CCS grooming analysis process associated with telephone central office half-tapping applications.

When to use this document

This document is written for all DMS-100 Family offices. More than one version of this document may exist. To determine whether you have the latest version of this document, check the release information in *DMS-100 Family Guide to Northern Telecom Publications*, 297-1001-001.

How Cutover Conversion Services documentation is organized

This document is part of Cutover Conversion Services documentation that supports the Northern Telecom Cutover Conversion Services. Cutover Conversion Services documentation is a subset of the DMS-100 Family library.

Cutover Conversion Services documentation consists of the following documents.

Number	Title
297-0301-300	<i>Cutover Conversion Services Customer Method of Procedures</i> Describes procedures for CCS customer activities
297-0301-301	<i>Cutover Conversion Services Grooming Method of Procedures</i> Describes the grooming analysis associated with central office half tapping applications.

The DMS-100 Family library is structured in numbered layers, and each layer is associated with an NT product. To understand Cutover Conversion Services, you need documents from the following layers:

- DMS-100 Family basic documents in the 297-1001 layer
- Cutover Conversion Services documents in the 297-0301 layer

Introduction

Half-tapping

When an operating company replaces an ESS switch, the operating company may wish to retain the existing COSMIC-type distributing frame or the older, conventional main distributing frame (MDF) for use with the replacement switch. In addition, the new modular-type frames can be used in a half-tap application. Using the existing distributing frame during the installation of a new Northern Telecom Digital Multiplexing Switch (DMS) family switch requires that the office implement a **half-tapping** strategy until the new switch goes into service.

Half-tapping involves running DMS line cables to a point where they can be directly terminated onto the line cables servicing the existing switch. At cutover, the old line cables are disconnected at the half-tap (or can be reused) and the DMS-100 family switch begins operation; the ESS switch is removed from service.

In a half-tapping application, the standard DMS-100 line equipment provisioning rules are not applied. Instead, the line assignments in the DMS are based primarily on the classes of service in the ESS; assignments do not consider existing line features or characteristics such as test lines or coin line fraud detection circuits.

Line assignments in the DMS-100 are derived through an algorithm which associates 64 lines of an ESS concentrator with 64 DMS lines (32 lines for each of the two Line Sub-Groups (LSG) per DMS line drawer), typically starting with the lowest concentrator in the ESS mapping to the two lowest LSGs and progressing through to the highest ESS concentrator. Figure 1-1 illustrates the ESS OE-to-DMS LEN association in a half-tapping application for COSMIC-type, conventional MDFs and Figure 1-2 shows the ESS OE-to-DMS LEN association in a half-tapping application for modular MDFs.

Lines in the ESS are half-tapped to the DMS in blocks of 32 lines using connectorized cable. In the case of a #1AESS or #1ESS switch, where a line concentrator can accommodate 32 or 64 lines, the half-tapping program associates one concentrator to one or two DMS-100 Line SubGroups (LSGs). (64-line concentrators are mapped to two LSGs in the same drawer;

32-line concentrators are mapped to single LSGs.) This line assignment methodology is referred to as one-to-one, or 1:1, as shown in Figure 1-3.

In half-tap arrangements, where mapping starts with the lowest concentrator to the lowest line subgroup(s) is not supported, then the telco must provide the CCS, with an ESS concentrator to DMS line subgroup relationship, for the entire office.

Note: A modular-type frame has only 64 lines per concentrator. A 32 line concentrator is not applicable to a modular-type frame.

The half-tapping arrangement dictates the subscriber assignments on the new DMS-100 equipment. Certain DMS-100 hardware provisioning restrictions and rules require that some existing service on the ESS switch be relocated to comply with the 1:1 line assignment methodology employed in the half-tap. In addition, the half-tapping scheme also requires that a particular circuit pack layout be established in the DMS-100.

CCS performs a **grooming analysis** to determine the service order impact of the half-tapping configuration.

Figure 1-1xxx
ESS OE-to-DMS LEN relationships for half-tapping (COSMIC-type, conventional frame)

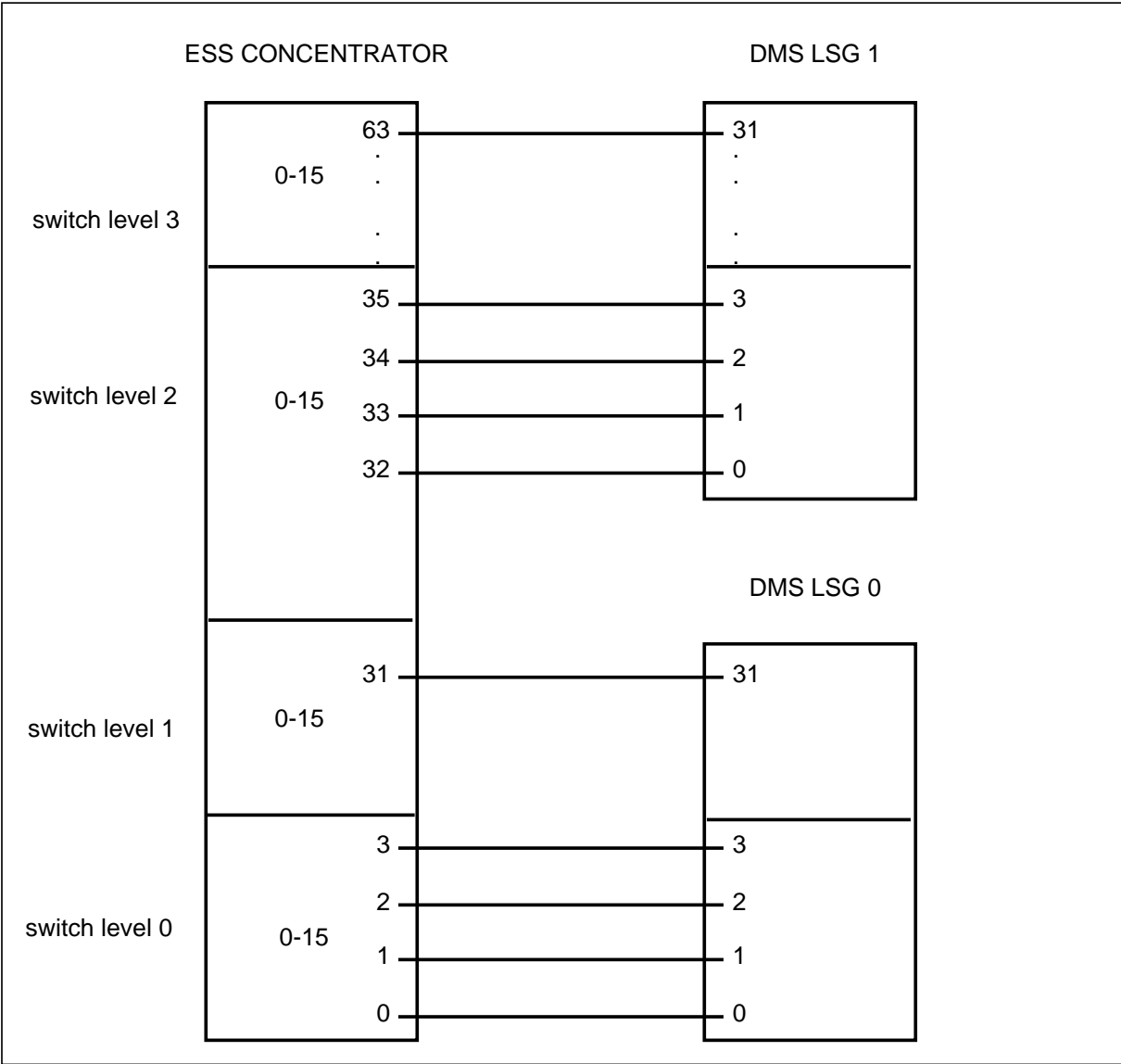
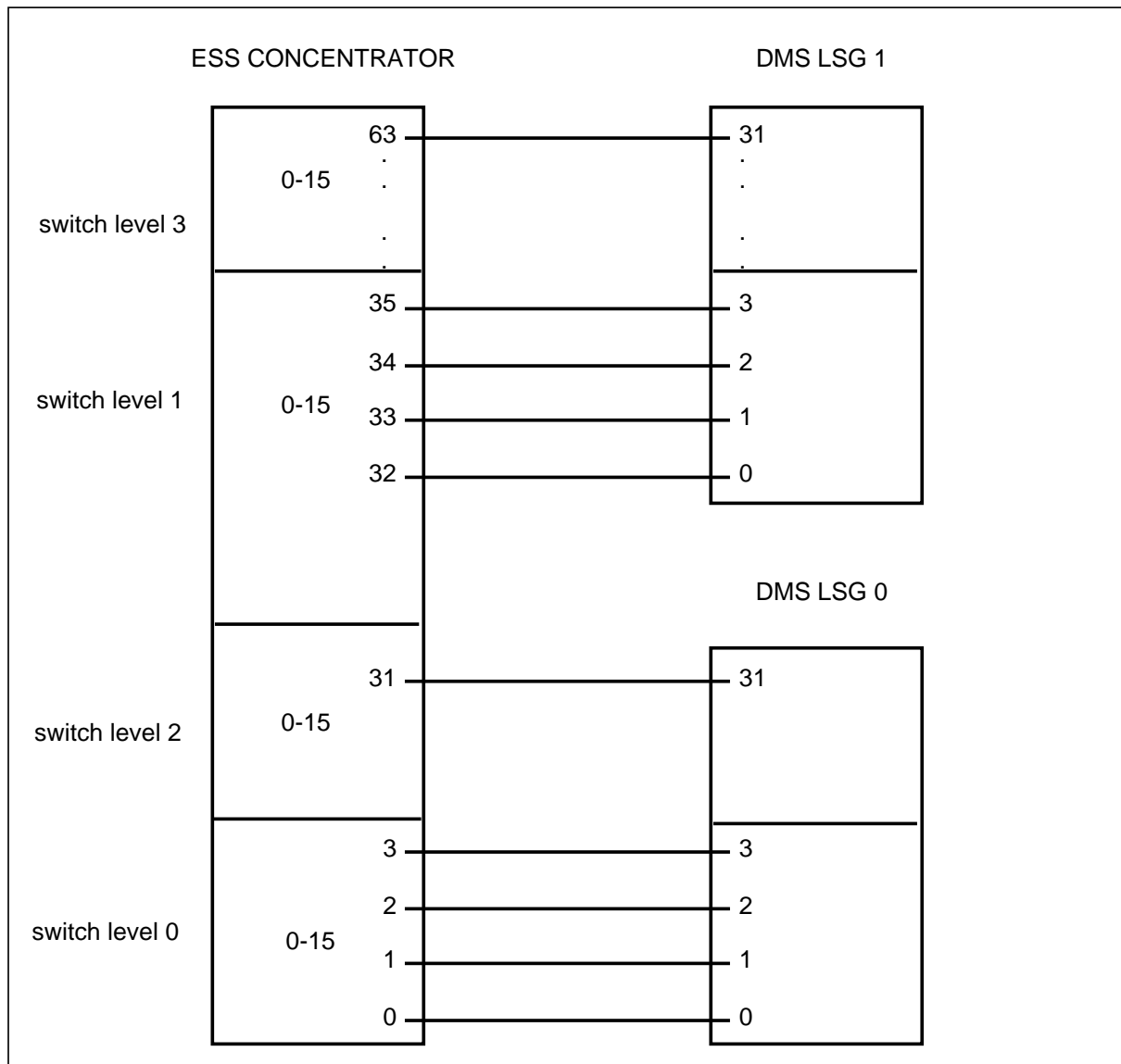

Figure 1-2xxx
ESS OE-to-DMS LEN relationships for half-tapping (modular frame)



Note 1: This is different from the COSMIC frame in that in each line drawer, line cards 16-31 of the even LSG (LSG0) are interchanged, one-for-one with line cards 0-15 of the odd LSG(LSG1).

Note 2: The modular frame is different from the COSMIC frame in that switch levels 1 and 2 change positions.

Figure 1-3xxx
1:1 line assignment methodology

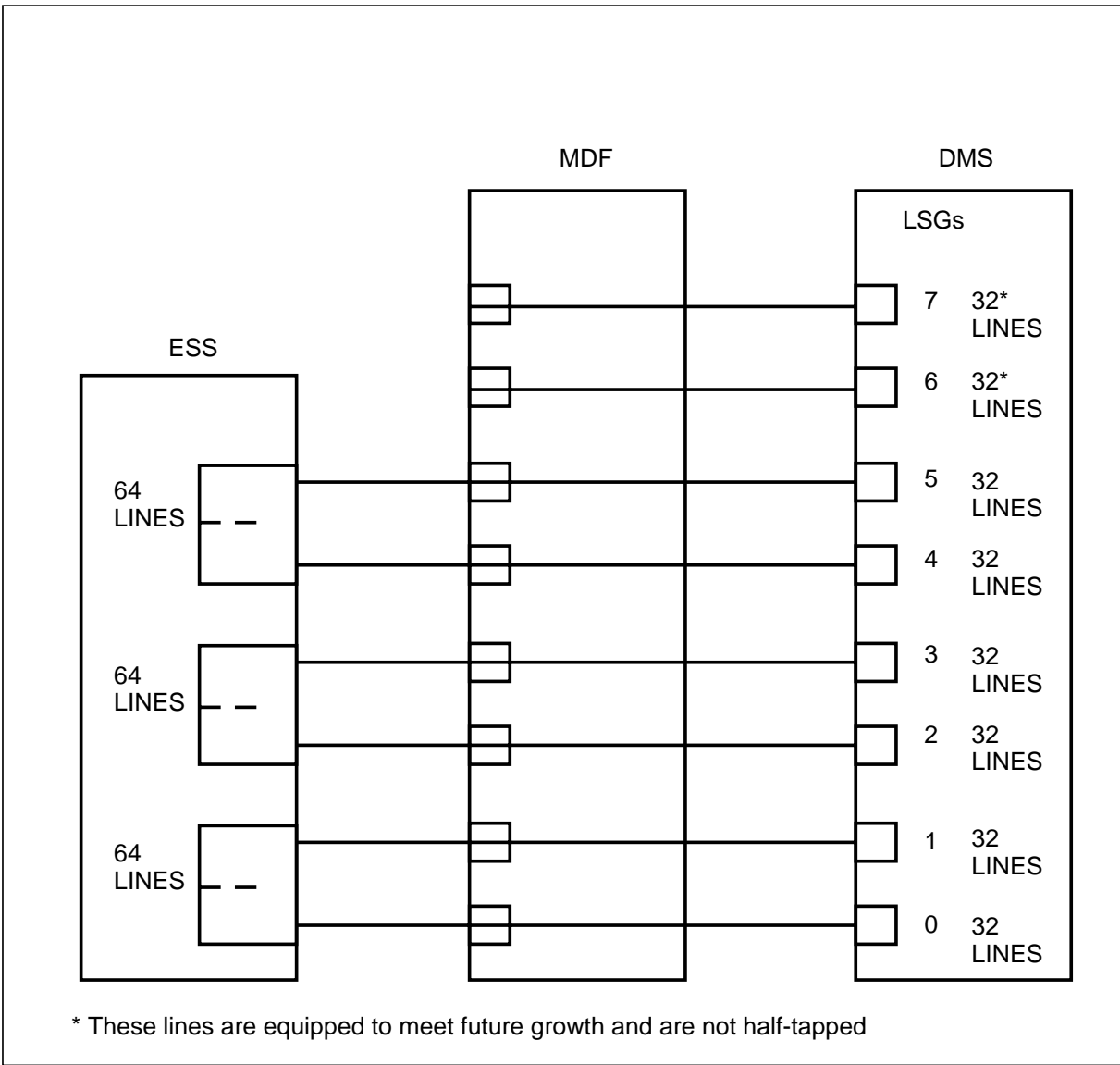

Grooming

The line assignments in the DMS-100 are based primarily on the classes of service in the ESS; the assignments do not consider existing line features or characteristics such as test reference lines or coin line fraud detection circuits. To avoid associating ESS lines to unavailable or inappropriate DMS line card drawer slots, the 1:1 line assignments must therefore be managed through pre-cutover **grooming** of the ESS (pre-grooming) and/or post-cutover grooming of the DMS (post-grooming).

Note: The line assignments derived from the 1:1 half-tapping algorithm will not match the DMS line assignments produced by the COSMOS database for the office. COSMOS implements standard DMS-100 equipment provisioning rules. Consequently, COSMOS should be updated to reflect the 1:1 line assignments.

When the operating company elects to implement a half-tap installation configuration, the Northern Telecom CCS department performs a grooming analysis of the ESS switch to establish the mapping between the ESS line links and the DMS LSGs before beginning any half-tap installation activities. The grooming analysis process identifies the service order impact of the half-tap arrangement on both the existing line service in the ESS and the new line service in the DMS-100. Northern Telecom also uses the output of the grooming process to either create or update the line equipment drawings associated with the new DMS-100 office.

Grooming checks can be performed with or without a Line Inventory (LNINV) table for the DMS-100 office. In most cases, however, the grooming process is performed long before an LNINV is developed or available for the new DMS-100 office.

Grooming analysis methods

The grooming analysis process requires Translation Data Assembler (TDA)-format data (usually on 9-track magnetic tape) from the #1AESS or #1ESS switch approximately 5-6 weeks prior to the Customer Information (CI) meeting for the new DMS-100 office. Figure 1-4 shows a general time line and sequence of activities for the grooming process. The time line shows the approximate dates relative to the CI meeting date for each step in the process.

The grooming process extracts the following elements from the TDA-format data :

- Directory Numbers (DNs)
- Office Equipment (OE) numbers
- Line Class Codes (LCCs)
- LCC expansion data (chart class column, originating major, terminating major)
- Start types (ground or loop).

Figure 1-4xxx
Grooming sequence of activities

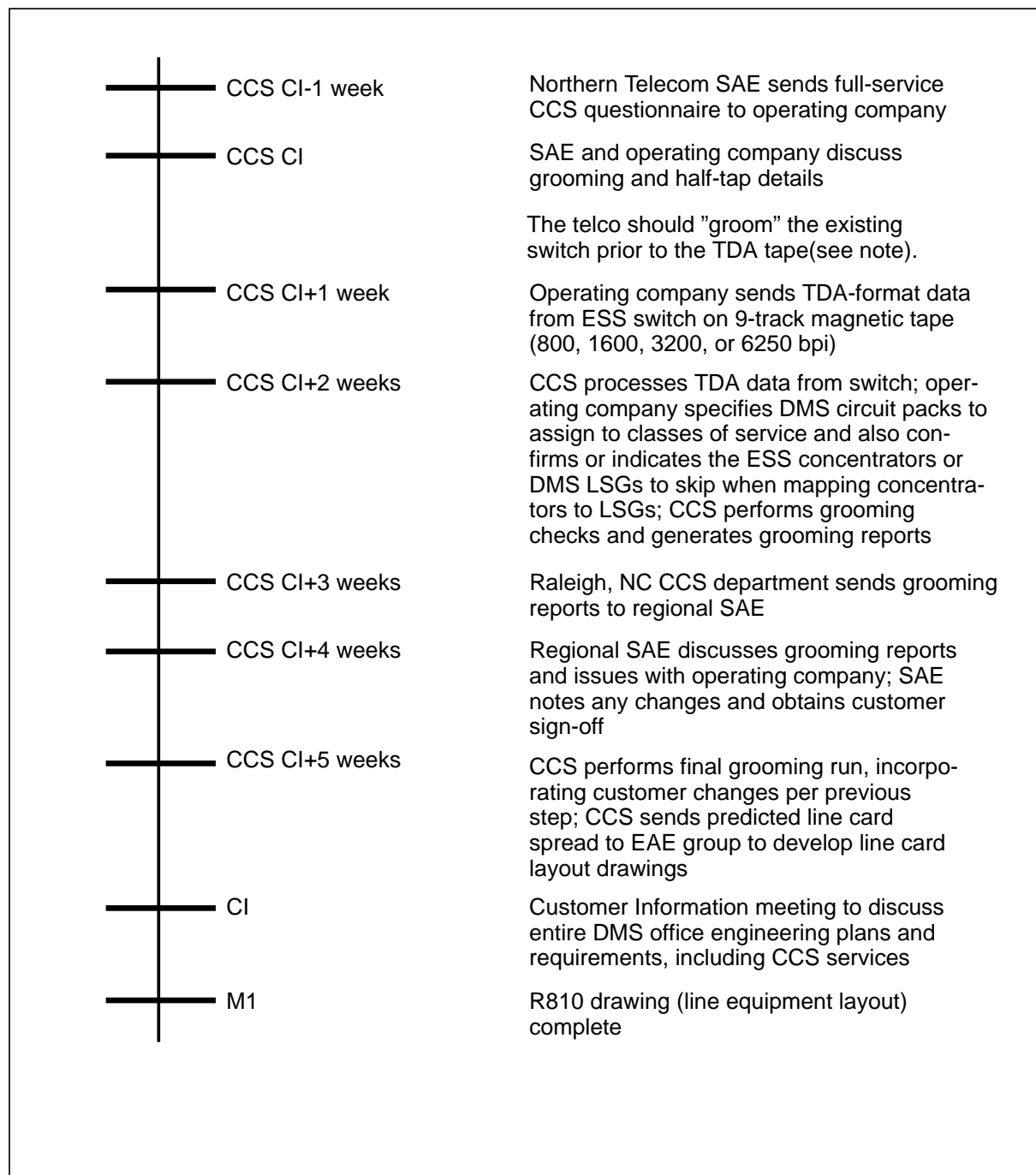

Note: If active ESS lines are on an ESS concentrator which will not be mapped to a corresponding DMS LSG then the telco should move those lines to spare OE's which will reside on an ESS concentrator that will be half-tapped.

The process maps each ESS OE to a DMS-100 LEN and a circuit pack. The grooming process compares the LENs and card codes assigned by the grooming process against Northern Telecom Engineering Manual rules to identify circuit pack conflicts. (In cases where an LNINV table is available for the new DMS-100 office, the grooming compares the LEN and card code for each working DN to information contained in the LNINV table for the same DN.)

The circuit pack discrepancy reports, together with other grooming reports, can be used by the operating company as a guide for relocating or reassigning service in the ESS or DMS as required to comply with the Northern Telecom half-tapping line assignment algorithm.

CCS performs the following tasks during the course of the grooming process:

- 1 Analyzes each frame in the ESS and identifies each concentrator that has at least one working DN and shows the Line Switch Frame (LSF), bay, concentrator, switch, and line ranges for each Line Link Network (LLN); also lists the concentrators that have no OEs assigned to them.
Note: The grooming report will not list any concentrators beyond the concentrator containing the last working DN for the office, therefore, the telco should ensure that at least one working DN exists in the last concentrator being half-tapped.
- 2 Identifies the unique classes of service (unique occurrences of Line Class Code (LCC), chart class column number, originating major and terminating major numbers, and start type (loop or ground)) associated with at least one working DN; also lists all unique classes of service that have no working DNs assigned to them.
- 3 Associates each unique class of service with a DMS card code, or circuit pack, which will support that class of service. The operating company specifies the circuit pack to assign to a particular class of service.
- 4 Maps the ESS concentrators to DMS LSGs, lowest to highest. Matching begins at frame 0 Line Concentrator Module (LCM) 0 by default unless the customer specifies another beginning frame; the grooming process can also skip (not assign) concentrators or LSGs if required. 64-line concentrators are mapped to two LSGs in the same drawer; 32-line concentrators are mapped to single LSGs.
- 5 Maps each ESS OE to a DMS LEN according to the 1:1 line assignment methodology for half-tapping applications.
- 6 Identifies the OEs that are assigned to more than one DN (multi-party lines).

- 7 Identifies the circuit pack conflicts that must be resolved to implement the half-tap installation configuration. Circuit pack conflicts exist when an ESS OE is mapped to a reserved LEN in the DMS, when an ESS OE is mapped to a test reference line in the DMS (LSG 0 Circuit 0), or when the circuit pack specified by the customer differs from the circuit specified in the LNINV table (if available) for the office.

For the most part, lines (OEs) in the ESS must be moved, or pre-groomed, to avoid their association to drawer slots in the DMS-100 occupied by:

- Power converter cards - 6X23AA (+48V, for coin line fraud detection)
- Message waiting power converter cards - 6X20AA
- Asynchronous Interface Line Cards (AILC) - 6X76AA
- Integrated Bit Error Rate Testing (IBERT) cards - 6X99AA
- Test line reference cards - 6X17AC
- Double-slotted cards- 6X71AA/6X71AB.

Grooming analysis reports

The Northern Telecom CCS grooming analysis process produces the following reports:

Frame Analysis - This report shows the OE, Line Switch Frame (LSF), bay, concentrator, switch, and line number ranges contained within each concentrator for each Line Link Network (LLN) in the ESS. The report also lists the concentrators with no working DNs assigned.

Unique Classes of Service - This report lists the unique classes of service associated with at least one working DN. Class of service is defined by the combination of the LCC expansion data (chart class column, originating major, terminating major) and start type associated with a given line. Since several different LCCs may have the same set of expansion data, the report groups together all LCCs with the same expansion data. In addition this report also shows the unique classes of service for which there are no working DNs assigned.

Unique Classes of Service with Card Codes - This report contains a list of all the unique classes of service that have at least one working DN along with the DMS-100 card code (circuit pack number) assigned to each class of service, based on input supplied by the customer. In cases where no card code information is specified by the customer, the grooming process assigns a default card code number. In addition, this report also shows the unique classes of service and card codes for which there are no working DNs assigned.

ESS Concentrator-to-DMS LSG Assignments - This report lists all the ESS concentrators to be half-tapped along with their associated DMS Line Subgroups (LSGs). The report also notes which concentrators were skipped, empty, or unassigned as well as any skipped LSGs.

ESS OE-DMS LEN Assignment-This report lists all of the ESS OEs to be half-tapped along with the associated line equipment numbers (LEN).

Multi-Party Service - This report lists all OE numbers with more than one DN assignment. The report notes the OE, DNs, LCC, and start type for each multi-party line.

ESS Ground Start- This report lists all OE numbers in the ESS that are identified as ground start lines.

ESS Loop-Start Coin- This report lists all OE numbers in the ESS that are identified as both coin and loop start lines.

ESS Grooming Impact - This report shows the ESS OEs (with assigned circuit pack type) that were mapped to LENs in the DMS that are **reserved** for different circuit pack types (such as the second slot of a double-slotted card).The report shows which ESS OEs need to be groomed, or relocated, to eliminate these circuit pack conflicts.

DMS Grooming Impact - If a Line Inventory (LNINV) table exists for the new DMS-100 office, the grooming process compares the circuit pack assigned by the grooming process for a given DN/OE to the circuit pack noted in the LNINV table for the half-tapped DN/LEN combination. This report identifies the OEs (with assigned circuit pack type) that were mapped to LENs in the DMS to which a different circuit pack is assigned according to the LNINV table for the office. This report is only available when a LNINV table exists for the DMS office.

Unavailable Spare OEs - This report lists the OEs that have no working DNs assigned (unequipped OE) and that are mapped to reserved LENs in the DMS (such as the second slot of a double-slotted card, or a test line).

Available Spare OEs - This report lists the OEs that have no working DNs assigned and that are mapped to LENs that may be used to resolve circuit pack conflicts.

Allowed Circuit Pack Mismatches - If an LNINV table exists for the office, then this report shows the allowable mismatches between the circuit packs assigned by the grooming process and the circuit pack specified by the LNINV table for a given OE-to-LEN mapping. Although the circuit packs are not identical, the mismatch is not considered a conflict since the circuit pack assigned by the grooming process can be used in place of the circuit pack specified by the engineering rules. This report is only available when a LNINV table exists for the DMS office.

Circuit Pack Usage - This report shows the circuit pack codes and the number of occurrence of each circuit pack for each DMS-100 Line Card Module (LCM).

Summary - This report contains a summary of data contained in each of the other reports generated during the grooming analysis process.

Method of procedure

General

The Northern Telecom grooming analysis process involves the following sequence of activities:

- 1 **Customer** (operating company) provides TDA-format data from the #1AESS or #1ESS (on 9-track magnetic tape) to Northern Telecom CCS (see Procedure 2-1).
- 2 Northern Telecom CCS analyzes tape data and produces frame analysis report, and class of service summary data for working lines.
- 3 **Customer** assigns DMS circuit packs to each unique class of service identified by the grooming process; indicates/verifies with Northern Telecom CCS the ESS concentrators and DMS LSGs to skip during concentrator-LSG mapping (see Procedure 2-2 and Procedure 2-3).
- 4 Northern Telecom CCS enters circuit pack data and performs grooming checks for each DMS LSG; Northern Telecom provides reports that detail the circuit pack conflicts, or discrepancies, between the customer-assigned circuit packs and the circuit packs specified by the Northern Telecom Engineering Manual rules. (If an LNINV table exists for the office, then CCS reports the discrepancies between customer-assigned circuit packs and the circuit packs called for by the LNINV table.)
- 5 Northern Telecom Systems Application Engineer (SAE) discusses grooming reports with operating company; customer changes are noted by the SAE and signed off.
- 6 Northern Telecom CCS runs final grooming checks with customer changes incorporated; process creates predicted line card spread in the DMS; CCS sends grooming results to Equipment Application Engineering group for use in creating the line card layout for the new DMS-100 office.
- 7 **Customer** uses grooming reports to perform grooming at the ESS and DMS.

Providing TDA-format data from ESS switch to CCS

Northern Telecom CCS requires Translation Data Assembler (TDA)-format data from the #1AESS or #1ESS office to perform the grooming analysis.

Procedure 2-1xxx Providing TDA-format data to CCS	
Step	Action
1	Make sure that TDA-format data from the ESS switch is written to tape at either 800 or 1600 bpi; for TDA-format data tapes from a #1ESS switch, please note the head-to-head table address on the tape reel.
2	Send the tape to the Northern Telecom CCS location performing the grooming survey.
End	

CCS then reads the TDA-format data from the tape and generates frame analysis reports, an ESS concentrator-to-DMS LSG mapping for the half-tap configuration and another report that details the unique classes of services requiring support in the DMS switch. Using these reports, the operating company can confirm or modify the concentrator skipping plan (see Procedure 2-2) and specify the DMS circuit pack desired to support each class of service in the DMS-100 (see Procedure 2-3).

Specifying concentrators to skip for concentrator-LSG mapping

One of the functions of the grooming analysis process involves mapping the ESS concentrators to DMS LSGs. When the operating company completes the CCS services questionnaire (approximately six weeks prior to the Customer Information (CI) meeting for the new DMS office), the operating company can specify the starting LSG for this mapping as well as any ESS concentrators or DMS LSGs that should be skipped during the mapping process. Or, if not indicated on the CCS questionnaire, this information can be provided after CCS makes an initial grooming analysis of the TDA-format data from the ESS switch.

The grooming process maps the lowest ESS concentrator to the lowest DMS LSG and the highest ESS concentrator to the highest DMS LSG, skipping any concentrators or LSGs as indicated by the operating company. If the ESS concentrator to DMS LSG mapping does not follow the standard rules, some telco grooming responsibilities are required. In half-tap arrangements, where mapping starts with the lowest concentrator to the lowest line subgroup(s) is not supported, then the telco must provide the CCS, with an ESS concentrator to DMS line subgroup relationship, for the entire office. After an initial pass through the TDA-format data, the Northern Telecom CCS grooming engineer will verify which, if any, concentrators to skip during the mapping process. When skipping is desired, LSGs are always skipped in pairs (0 and 1) by line drawers; 64-line concentrators are mapped

to two LSGs in the same drawer; 32-line concentrators are mapped to single LSGs.

Since the ESS concentrator-to-DMS LSG mapping is needed during the half-tap installation process, the operating company must sign off on the final mapping prior to the K-date for the new office.

Procedure 2-2xxx Confirming/indicating concentrators/LSGs to skip	
Step	Action
1	Review frame analysis reports and concentrator-to-LSG mappings (produced by CCS after Procedure 2-1)
2	Indicate to CCS grooming engineer which ESS concentrators or DMS LSGs to skip for final concentrator-to-LSG mapping. If a preliminary skipping plan has already been implemented in the analysis, then review, confirm, and modify as required.
End	

If necessary, CCS can then update the concentrator-to-LSG mapping as required to incorporate any changes or skips, according to the operating company's analysis of the initial concentrator-to-LSG mapping.

Assigning circuit packs to classes of service

Northern Telecom CCS reads the TDA-format data from the tape and identifies the unique classes of service associated with at least one working DN. The unique class of service consists of the Line Class Code (LCC), chart class column number, originating major, terminating major, and start type. The report/form groups together all LCCs with the same expansion data.

Figure 2-1 shows a segment from the Unique Classes of Service report.

Northern Telecom CCS requests that the operating company specify the circuit pack to use for each of the identified classes of service for working DNs in the ESS office. Northern Telecom CCS uses this information to identify grooming issues by comparing the circuit pack specified by the operating company for a given OE to the circuit pack specified by the Northern Telecom Engineering Manual rules. (If the LNINV table exists for the office, then CCS compares the customer-specified circuit pack against the circuit pack called for in the LNINV table.)

2-4 Method of procedure

Note: Initially, Northern Telecom CCS will run the grooming checks on the DMS LSGs by using the default circuit pack assigned during the grooming process. For ground start lines, the process assigns a 6X18AB circuit pack by default; for loop start lines, the default circuit pack is a 6X17AC card. In this case, the card codes can be verified, and corrected, as required.

Figure 2-1xxx
Assigning circuit packs to classes of service

Unique Classes of Service							Page #
Office Name (H#)							Date
ESS						DMS-100	
LCC	Chart Column	Orig. Major	Term. Major	Start Type	Number of Occurrences	:	Card Code (6X17AC, 6X18AB ...)
000	0	0	0	Loop	2	:	██████████
17Q	55	4	4	Loop	59	:	██████████
1F9	62	4	4	Loop	2	:	██████████
TF9							
1FR	2	4	4	Loop	12800	:	██████████
TFR							
TFK							
FR6							

Procedure 2-3xxx	
Procedure title	
Step	Action
1	Using the report form provided by CCS after the initial grooming analysis pass (see Figure 2-1), enter the circuit pack number (or specify a different circuit pack) for each identified class of service.
2	Return the completed form to the Northern Telecom CCS location performing the grooming survey.
End	

Northern Telecom CCS then enters circuit pack data provided by the operating company and performs grooming checks for each DMS LSG. CCS provides reports that detail the circuit pack conflicts, or discrepancies, between the customer-assigned circuit packs and the circuit packs specified by the Northern Telecom Engineering Manual rules. (If an LNINV table exists for the office, then CCS reports the discrepancies between customer-assigned circuit packs and the circuit packs called for by the LNINV table.)

Resolving circuit pack conflicts (grooming)

The Northern Telecom CCS grooming analysis process produces several reports that identify circuit pack conflicts which must be resolved at either the ESS and/or the DMS to successfully implement the half-tap configuration. The reports of particular value during the physical grooming activity by the operating company are:

- 1 Circuit Pack Conflicts - ESS Impacting
- 2 Circuit Pack Conflicts - DMS Impacting (only when LNINV table exists for office or when customer specifies a particular circuit pack location on the DMS)
- 3 DMS-100 Test Lines With a DN Assigned
- 4 Spare or Unequipped OEs - Available
- 5 Allowed Circuit Pack Conflicts.

Refer to the chapter “Interpreting the grooming analysis reports”, which follows, for information on interpreting and applying the information contained in these reports to resolve circuit pack conflicts.

Interpreting the grooming analysis reports

Circuit pack summary report

The grooming process produces one of two types of summary reports, depending on whether the DMS-100 LNINV table was available during the grooming. Both reports, however, provide a summary of data contained in all the other grooming reports.

Probably, the data summary item of greatest significance to on-site ESS grooming personnel is the summary data for the ESS Impacts. These data indicate the amount of grooming required at the ESS side of the half-tap. The specific locations of the OEs that need to be groomed are noted in another report, "Circuit pack conflicts - ESS impacting."

Figure 3-1 shows a segment from the Circuit Pack Summary report for a grooming process in which no LNINV table was available; Figure 3-2 shows a summary report from a grooming process in which the LNINV table was used.

Figure 3-1xxx
Circuit pack summary report (without LNINV)

Circuit Pack Summary Report Office Name (H#)	Page # Date		

Number of Working DNs:	43249		
DMS Circuit Packs Required:			
6X17AC	42716		
6X18AB	1445		

Total	44161		
ESS Impacts (the following cards were found where other service was expected):			
	Number of Conflicts	Required Pack	Number of Occurrences
Test lines	69	6X17AC	69

Total			69
Circuit Packs That Were Mapped Correctly:			
6X17AC			42647
6X18AB			1445

Total			44092
Spare Cards:			
Available Spare OEs:			494
Unavailable Spare OEs:			10

Total			504

Figure 3-2xxx
Circuit pack summary report (withLNINV)

Circuit Pack Summary Report Office Name (H#)	Page # Date		

Number of Working DNs:	43249		
DMS Circuit Packs Required:			
6X17AC	42716		
6X18AB	1445		

Total	44161		
Circuit Packs in LNINV:			
6X17AC	40734		
6X18AB	2280		
6X19AA	3192		
6X20AA	152		
6X21AC	1520		
6X71AB	304		
6X99AA	1		

Total	48183		
ESS Impacts (the following cards were found where other service was expected):			
	Number of Conflicts	Required Pack	Number of Occurrences
Test lines	69	6X17AC	69
6X20AA	277	6X17AC	277
6X71AB	559	6X17AC	559
-----			-----
Total			905

**Figure 3-2
Circuit pack summary report (with LNINV) (continued)**

Circuit Pack Summary Report Office Name (H#)	Page # Date																								

DMS Impacts (the following cards were found where other service was expected):																									
	<table border="0" style="width: 100%;"> <thead> <tr> <th style="width: 40%;"></th> <th style="width: 20%; text-align: center;">Number of Conflicts</th> <th style="width: 20%; text-align: center;">Required Pack</th> <th style="width: 20%; text-align: center;">Number of Occurrences</th> </tr> </thead> <tbody> <tr> <td style="padding-left: 40px;">6X21AC</td> <td style="text-align: center;">1399</td> <td style="padding-left: 40px;">6X18AB</td> <td style="text-align: center;">1</td> </tr> <tr> <td style="padding-left: 40px;">6X19AA</td> <td style="text-align: center;">245</td> <td style="padding-left: 40px;">6X17AC</td> <td style="text-align: center;">1398</td> </tr> <tr> <td></td> <td></td> <td style="padding-left: 40px;">6X18AB</td> <td style="text-align: center;">245</td> </tr> <tr> <td style="padding-left: 40px;">6X17AC</td> <td style="text-align: center;">1197</td> <td style="padding-left: 40px;">6X18AB</td> <td style="text-align: center;">1197</td> </tr> <tr> <td colspan="3">Total</td> <td style="text-align: center;">2841</td> </tr> </tbody> </table>		Number of Conflicts	Required Pack	Number of Occurrences	6X21AC	1399	6X18AB	1	6X19AA	245	6X17AC	1398			6X18AB	245	6X17AC	1197	6X18AB	1197	Total			2841
	Number of Conflicts	Required Pack	Number of Occurrences																						
6X21AC	1399	6X18AB	1																						
6X19AA	245	6X17AC	1398																						
		6X18AB	245																						
6X17AC	1197	6X18AB	1197																						
Total			2841																						

Circuit Packs That Were Mapped Correctly:																									
	<table border="0" style="width: 100%;"> <tbody> <tr> <td style="padding-left: 40px;">6X17AC</td> <td style="text-align: right;">42647</td> </tr> <tr> <td style="padding-left: 40px;">6X18AB</td> <td style="text-align: right;">1445</td> </tr> <tr> <td colspan="2">-----</td> </tr> <tr> <td>Total</td> <td style="text-align: right;">44092</td> </tr> </tbody> </table>	6X17AC	42647	6X18AB	1445	-----		Total	44092																
6X17AC	42647																								
6X18AB	1445																								

Total	44092																								

Spare Cards:																									
	<table border="0" style="width: 100%;"> <tbody> <tr> <td style="padding-left: 40px;">Available Spare OEs:</td> <td style="text-align: right;">494</td> </tr> <tr> <td style="padding-left: 40px;">Unavailable Spare OEs:</td> <td style="text-align: right;">10</td> </tr> <tr> <td colspan="2">-----</td> </tr> <tr> <td>Total</td> <td style="text-align: right;">504</td> </tr> </tbody> </table>	Available Spare OEs:	494	Unavailable Spare OEs:	10	-----		Total	504																
Available Spare OEs:	494																								
Unavailable Spare OEs:	10																								

Total	504																								

Allowable Mismatches:																									
	<table border="0" style="width: 100%;"> <thead> <tr> <th style="width: 60%; text-align: left;">Required Circuit Pack</th> <th style="width: 40%; text-align: left;">Allowable Circuit Pack</th> </tr> </thead> <tbody> <tr> <td style="padding-left: 40px;">6X17AC</td> <td style="padding-left: 40px;">6X18AA</td> </tr> <tr> <td></td> <td style="padding-left: 40px;">6X18AB</td> </tr> </tbody> </table>	Required Circuit Pack	Allowable Circuit Pack	6X17AC	6X18AA		6X18AB																		
Required Circuit Pack	Allowable Circuit Pack																								
6X17AC	6X18AA																								
	6X18AB																								

Frame analysis - OE range information

This report shows the OE ranges and the ranges of the identifying values for LSFs, bays, concentrators, switches, and lines (or levels) within each Line Link Network in the ESS. The report also shows the number of lines in each concentrator and the number of DMS LSGs that will be assigned to each concentrator by the grooming process.

Figure 3-3 below identifies the components of ESS OE numbers and DMS LENS. Figure 3-4 shows a segment from this report.

Figure 3-3xxx
ESS OE and DMS LEN numbers

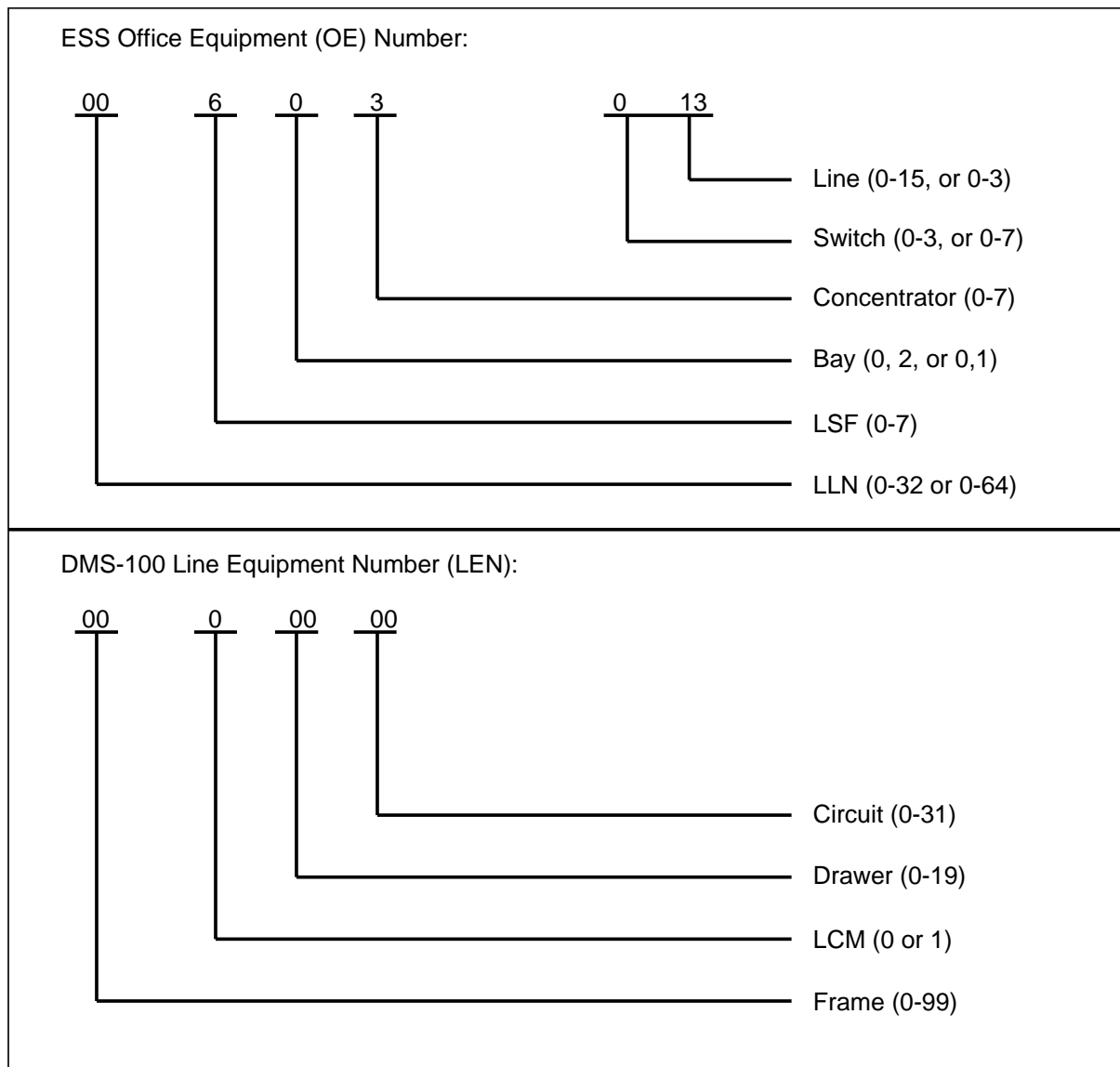

Figure 3-4xxx
Frame analysis - OE range information

Circuit Pack Summary Report	Page #
Office Name (H#)	Date

LLN : 00	
OE Range : 00 000 001 to 00 603 013	
LSF Range :0 - 6	
Bay Range :0 ,2	
Conc Range :0 - 7	
Switch Range :0 - 3	
Line Range :0 - 15	
Lines per Concentrator : 64	
2 LSGs will be assigned to a Concentrator	
LLN : 00	
OE Range : 01 000 000 to 01 527 315	
LSF Range :0 - 5	
Bay Range :0 ,2	
Conc Range :0 - 7	
Switch Range :0 - 3	
Line Range :0 - 15	
Lines per Concentrator : 64	
2 LSGs will be assigned to a Concentrator	

Frame analysis - concentrators with no assigned DNs

This report identifies the concentrators in the ESS for which no working DNs are assigned. The operating company can specify whether these concentrators should be mapped to DMS LSGs or skipped (not mapped) during the grooming process.

Figure 3-5 shows a segment from this report.

Figure 3-5xxx

Frame analysis - concentrators with no assigned working DNs

Frame Analysis - Concentrators with no assigned working DNS	Page #
Office Name (H#)	Date

Concentrator(s)	

00 602 xxx	
00 604 xxx	
00 605 xxx	
00 606 xxx	
00 607 xxx	
00 620 xxx	
00 621 xxx	
00 622 xxx	
00 623 xxx	
00 624 xxx	
00 625 xxx	
00 626 xxx	
00 627 xxx	

Concentrator - LSG mapping

This report shows the DMS LSGs (or drawers) that the grooming process assigns to each ESS concentrator to be half-tapped. The grooming process maps 64-line concentrators to two LSGs in the same drawer and 32-line concentrators to one LSG. In Figure 3-6, for example, each ESS concentrator is mapped to two LSGs, as shown by the double-column entry under the LSG(s) heading.

In the highlighted record in Figure 3-6, the lines in ESS concentrator 5 in Bay 2 in LSF 5 are mapped to DMS LSGs 10 and 11 of LCM 0 in Frame 13.

The report also shows the ESS concentrators that were skipped (not mapped) during the grooming process. For example, in Figure 3-6, note that

ESS concentrators 0-7 in Bay 0 of LSF 6 were not mapped to DMS LSGs. The report provides notes on unmapped concentrators:

* **Skipped -- Unused.** - indicates concentrator was empty, or contained no working lines.

* **Skipped by User.** - indicates concentrator contained lines but was not mapped. In addition, the report shows the empty concentrators that were mapped to DMS LSGs. In this case, the report provides the following note:

In addition, the report shows the empty concentrators that were mapped to DMS LSGs. In this case, the report provides the following note:

* **Empty - Added by User.** Finally, if an 'even' LSG is skipped and the next concentrator to be mapped contains 64 lines, the process will skip the 'odd' LSG and begin mapping the concentrator to the next 'even' LSG. The report will indicate this action by the following note:

Finally, if an "even" LSG is skipped and the next concentrator to be mapped contains 64 lines, the process will skip the "odd" LSG and begin mapping the concentrator to the next "even" LSG. The report will indicate this action by the following note:

* **Odd LSG skipped.**

Figure 3-6xxx
Concentrator - LSG Mapping

Concentrator - LSG Mapping			Page #
Office Name (H#)			Date
<u>Concentrator</u>	<u>LSG(s)</u>		<u>Notes</u>
00 525 xxx	13 0 10 xx	13 0 11 xx	
00 526 xxx	14 0 02 xx	14 0 03 xx	
00 527 xxx	15 0 18 xx	15 0 19 xx	
00 600 xxx	---	---	*Skipped by User.
00 601 xxx	---	---	*Skipped by User.
00 602 xxx	---	---	*Skipped -- Unused.
00 603 xxx	---	---	*Skipped by User.
00 604 xxx	---	---	*Skipped -- Unused.
00 605 xxx	---	---	*Skipped -- Unused.
00 606 xxx	---	---	*Skipped -- Unused.
01 000 xxx	05 1 12 xx	05 1 13 xx	
01 001 xxx	07 0 08 xx	07 0 09 xx	
01 002 xxx	05 1 16 xx	05 1 17 xx	
01 003 xxx	07 0 12 xx	07 0 13 xx	
01 004 xxx	06 0 00 xx	06 0 01 xx	
01 005 xxx	07 0 16 xx	07 0 17 xx	
01 006 xxx	06 0 04 xx	06 0 05 xx	
01 007 xxx	07 0 00 xx	07 0 01 xx	
01 020 xxx	05 1 14 xx	05 1 15 xx	
01 021 xxx	07 0 10 xx	07 0 11 xx	
01 022 xxx	05 1 18 xx	05 1 19 xx	
01 023 xxx	07 0 14 xx	07 0 15 xx	
01 024 xxx	06 0 02 xx	06 0 03 xx	
01 025 xxx	07 0 18 xx	07 0 19 xx	
01 026 xxx	06 0 06 xx	06 0 07 xx	

Unique classes of service

Class of service is defined by the combination of the following:

- Line Class Code (LCC)
- chart class column number
- originating major
- terminating major
- start type (loop or ground)

The grooming process looks at the records on the TDA-format tape and extracts the unique classes of service associated with working DNs. When two or more LCCs are associated with the same set of LCC expansion data (chart class column, originating major, terminating major, and start type), they are considered equivalent LCCs.

The report shows all unique classes of service that have at least one working DN assigned to them; the report groups equivalent LCCs together. For example, Figure 3-7, LCCs 1FR, TFR, TFK, and FR6 each have the same set of expansion data and start type. In addition, this report notes the number of lines associated with a given class of service.

This report contains a column in which the operating company can enter the DMS card code most appropriate for supporting a particular class of service.

Figure 3-7xxx
Unique classes of service

Unique Classes of Service						Page #
Office Name (H#)						Date
ESS						DMS-100
LCC	Chart Column	Orig. Major	Term. Major	Start Type	Number of Occurrences	Card Code (6X17AC, 6X18AB ...)
000	0	0	0	Loop	2	: _____
17Q	55	4	4	Loop	59	: _____
1F9 TF9	62	4	4	Loop	2	: _____
1FR TFR TFK FR6	2	4	4	Loop	12800	: _____
1M9	64	4	4	Loop	11	: _____
1MR TO9 TMR TMK TMC TMB 1MB	1	4	4	Ground	618	: _____
2FR FR7	2	6	6	Loop	65	: _____

Unique classes of service with card codes

This report is identical to the Unique Classes of Service report except that the card code column contains either the card codes specified by the operating company to be used for each class of service or the default card codes assigned to each class of service by the grooming process.

Figure 3-8 shows a segment from this report.

Figure 3-8xxx
Unique classes of service with card codes

Unique Classes of Service						Page #
Office Name (H#)						Date
ESS						DMS-100
LCC	Chart Column	Orig. Major	Term. Major	Start Type	Number of Occurrences	Card Code (6X17AC, 6X18AB ...)
000	0	0	0	Loop	2	: 6X17AC
17Q	55	4	4	Loop	59	: 6X17AC
1F9 TF9	62	4	4	Loop	2	: 6X17AC
1FR TFR TFK FR6	2	4	4	Loop	12800	: 6X17AC
1M9	64	4	4	Loop	11	: 6X17AC
1MR TO9 TMR TMK TMC TMB 1MB	1	4	4	Ground	618	: 6X18AB
2FR FR7	2	6	6	Loop	65	: 6X17AC

LCCs without working DN assignments

This report shows the unique classes of service which have no working DNs assigned to them; they are unused. Like the Unique Classes of Service reports(s), this report groups together the equivalent LCCs which have no working DNs.

Figure 3-9 shows a segment from this report.

Figure 3-9xxx
LCCs without working DN assignments

LCCs without working DN assignments					Page #
Office Name (H#)					Date
LCC	Chart Column	Orig. Major	Term. Major	Start Type	
000	0	0	0	Ground	
17A	67	4	4	Ground	
1F9 TF9	62	4	4	Ground	
1FR TFR TFK FR6	2	4	4	Ground	
1M9	64	4	4	Ground	
1PC 1SP 1PO 1PN	7	29	21	Ground	
1PM	47	29	24	Ground	
1PM	47	29	24	Loop	
2F9	62	6	6	Ground	

Test lines with a DN assigned

For each LCM in the DMS, LSG 0 - circuit 0 is 'reserved' as a test reference line; no working DNs can be assigned to this LEN in each LCM.

This report lists the ESS OEs which the grooming process has mapped to LSG 0 - circuit 0 in each LCM. These ESS OEs will need to be relocated in the ESS to avoid their association to these reserved LENS in the DMS. Reference the "Spare or Unequipped OEs - Available" report for OEs to which the service can be reassigned in the ESS.

Figure 3-10 shows a segment from this report.

Figure 3-10xxx
Test lines with a DN assigned

DMS-100 Test Lines with a DN Assigned				Page #
Office Name (H#)				Date
DMS (LNINV)			ESS	
LEN	Circuit Pack	OE	Pred. Circuit Pack	DN
01 1 00 00	6X17AC	00 003 000	6X17AC	3532262
01 1 00 00	6X17AC	00 102 000	6X17AC	3530817
02 0 00 00	6X17AC	00 105 000	6X17AC	3533806
03 0 00 00	6X17AC	00 202 000	6X17AC	3531854
04 1 00 00	6X17AC	00 205 000	6X17AC	3322727
07 0 00 00	6X17AC	00 305 000	6X17AC	3551602
11 1 00 00	6X17AC	00 406 000	6X17AC	3539165
13 0 00 00	6X17AC	00 501 000	6X17AC	3538783
14 0 00 00	6X17AC	00 506 000	6X17AC	3360736
06 0 00 00	6X17AC	01 004 000	6X17AC	3550220
07 1 00 00	6X17AC	01 007 000	6X17AC	3533781
08 1 00 00	6X17AC	01 004 000	6X17AC	3558306
10 0 00 00	6X17AC	01 107 000	6X17AC	3559565
09 0 00 00	6X17AC	01 206 000	6X17AC	3554676
01 0 00 00	6X17AC	01 306 000	6X17AC	3554665
15 1 00 00	6X17AC	01 401 000	6X17AC	3557661
14 1 00 00	6X17AC	01 500 000	6X17AC	3378960
16 0 00 00	6X17AC	01 503 000	6X17AC	3519961
02 1 00 00	6X17AC	02 001 000	6X17AC	3534689
03 1 00 00	6X17AC	02 006 000	6X17AC	3555240
05 0 00 00	6X17AC	02 101 000	6X17AC	3530780
17 0 00 00	6X17AC	02 400 000	6X17AC	3551759
22 0 00 00	6X17AC	04 301 000	6X17AC	3519961

Circuit pack conflicts - ESS impacting

The grooming process determines the service order impact of half-tapping by performing a series of grooming checks on each LSG in the DMS. The grooming checks can be performed with or without the Line Inventory (LNINV) table from the DMS.

Note: In most cases, the grooming process will occur long before a LNINV is developed or available for the new DMS office.

For a grooming survey in which no LNINV table is available, the grooming process checks the OE, LEN, DN, and card code combination against the Northern Telecom Engineering Manual rules to identify circuit pack conflicts associated with the OE-to-LEN mappings. The process uses the following rules to determine circuit pack conflicts associated with OE-to-LEN mappings:

- 1 A 6X17AC circuit pack is required in LSG 00 circuit 00 of every LCM for test line reference purposes. No OEs can be mapped to these LENSs.
- 2 If a 6X18AB card is required for Coin Line Fraud Detection, a 6X23AA +48V power converter circuit pack is required in circuits 0 and 16 of the 'odd' LSG. No OEs can be mapped to these LENSs if a 6X18AB card is mapped to this drawer.
- 3 If a 6X19AA card is required for Message Waiting service, a 6X20AA power converter circuit pack is required in circuits 0 and 16 of the 'odd' LSG. No OEs can be mapped to these LENSs if a 6X19AA card is mapped to this drawer.
- 4 If a 6X71AA/6X71AB card is required for Data Path service, two cards are required. The 'even' circuit is assigned while the 'odd' circuit is reserved. No OE can be mapped to the reserved circuit.

The report identifies OE-to-LEN mappings and associated circuit packs that violate these rules.

For a grooming survey in which the LNINV table is available, the process compares the OE, LEN, DN, and card code combination for lines in the ESS against the LEN and card code combination for the same lines in the DMS. The process identifies any circuit pack conflicts in which an ESS OE is mapped to a DMS LEN that is either reserved for a specific circuit pack type, or contains a different circuit pack than the one specified for the ESS OE. (Circuit Pack Conflicts other than those resulting from the assignment of OEs to reserved LENSs are noted in another report, "Circuit Conflicts - DMS Impacting.")

For example, in the DMS-100, circuits 0 and 16 of the 'odd' LSGs are reserved for the power converter cards 6X20AA and 6X23AA associated with Message Waiting service and Coin Line Fraud Detection service,

respectively. Similarly, circuits 15 and 31 of 'even' LSGs are reserved for the 6X71AA(AB) Data Unit circuit packs.

The Circuit Pack Conflicts - ESS Impacting report notes the OEs that are mapped to reserved LENS in the DMS. Service for these lines in the ESS will need to be reassigned or relocated to comply with the half-tapping scheme.

Figure 3-11 shows a segment from this report.

Figure 3-11xxx
Circuit pack conflicts - ESS impacting

Circuit Pack Conflicts - ESS Impacting					Page #
Office Name (H#)					Date
DMS (LNINV)			ESS		
LEN	Circuit Pack	OE	Pred. Circuit Pack	DN	
00 0 01 00	6X20AA	00 000 200	6X17AC	3538655	
00 0 01 16	6X20AA	00 000 300	6X17AC	3320197	
01 0 16 15	6X71AB	00 001 015	6X17AC	3552472	
01 0 16 31	6X71AB	00 001 115	6X17AC	3536854	
01 1 01 00	6X20AA	00 003 200	6X17AC	3557464	
01 1 01 16	6X20AA	00 003 300	6X17AC	3559548	
00 0 08 15	6X71AB	00 004 015	6X17AC	3551584	
00 0 08 31	6X71AB	00 004 115	6X17AC	3555505	
01 1 08 15	6X71AB	00 007 015	6X17AC	3556743	
01 1 08 31	6X71AB	00 007 115	6X17AC	3550591	
01 0 18 15	6X71AB	00 021 015	6X17AC	3555384	
01 0 18 31	6X71AB	00 021 115	6X17AC	3554279	
00 0 06 15	6X71AB	00 022 015	6X17AC	3551234	
00 0 06 31	6X71AB	00 022 115	6X17AC	3553485	
00 0 11 00	6X20AB	00 024 200	6X17AC	3554091	
00 0 11 16	6X20AB	00 024 300	6X17AC	3557234	
01 1 06 15	6X71AB	00 025 015	6X17AC	3557638	
01 1 06 31	6X71AB	00 025 115	6X17AC	3559949	
01 1 11 00	6X20AA	00 027 200	6X17AC	3559331	
01 1 11 16	6X20AA	00 027 300	6X17AC	3553757	
04 0 11 00	6X20AA	00 127 200	6X17AC	3556432	
04 0 11 16	6X20AA	00 127 300	6X17AC	3559903	
04 0 16 15	6X71AB	00 203 015	6X17AC	3557876	
04 0 16 31	6X71AB	00 203 115	6X17AC	3554408	

Circuit pack conflicts - DMS impacting

This report can be produced only when a Line Inventory (LNINV) table is available for the DMS office. The grooming process checks the OE, LEN, DN, and circuit pack assignments against the assignments contained in the LNINV table. When the LNINV table shows a different circuit pack assignment for a given OE-to-LEN mapping than the one specified by the operating company (or the default circuit pack assignment), the process reports the discrepancy.

The circuit pack conflicts noted in this report can be resolved either by reassigning the service in the DMS, or keeping the DMS assignments in place and relocating the ESS service conflicts.

The operating company can also specify a circuit pack substitution list. This would allow, for example, a 6X18AA or 6X18AB card to be used in place of a 6X17AC card. Before reporting a circuit pack conflict, the process checks whether a circuit pack conflict is allowable, based on the allowed mismatches list provided by the operating company. If so, the conflict is not reported as a true DMS Impacting conflict; rather, the mismatch is noted in a separate report, "Allowed Circuit Pack Mismatch" report.

Figure 3-12 shows a segment from this report.

Figure 3-12xxx
Circuit pack conflicts - DMS impacting

Circuit Pack Conflicts - DMS Impacting					Page #
Office Name (H#)					Date
DMS (LNINV)			ESS		
LEN	Circuit Pack	OE	Pred. Circuit Pack	DN	
34 0 05 31	6X21AC	07 102 315	6X17AC	337013	
35 1 00 10	6X21AC	07 103 010	6X17AC	3512238	
35 1 01 12	6X19AA	07 103 212	6X18AB	3320574	
35 1 01 26	6X21AC	07 103 310	6X17AC	3556659	
35 1 01 28	6X19AA	07 103 312	6X18AB	3535000	
34 0 08 30	6X21AC	07 104 114	6X17AC	3559992	
34 0 09 12	6X17AC	07 104 212	6X18AB	3329456	
34 0 09 31	6X21AC	07 104 315	6X17AC	3373908	
35 1 04 31	6X21AC	07 105 115	6X17AC	3534979	
35 1 05 12	6X17AC	07 105 212	6X18AB	3518000	
35 1 05 31	6X21AC	07 105 315	6X17AC	3515685	
36 0 16 30	6X21AC	07 106 114	6X17AC	3535535	
36 0 17 12	6X17AC	07 106 212	6X18AB	3552302	
34 0 10 10	6X21AC	07 124 010	6X17AC	3558240	
34 0 11 12	6X19AA	07 124 212	6X18AB	3326551	
34 0 11 20	6X17AC	07 124 304	6X18AB	3379884	
34 0 11 26	6X21AC	07 124 310	6X17AC	3516007	
35 1 06 30	6X21AC	07 125 114	6X17AC	3322527	
35 1 07 12	6X17AC	07 125 212	6X18AB	3322627	
35 1 07 31	6X21AC	07 125 315	6X17AC	3556622	
36 0 18 30	6X21AC	07 126 114	6X17AC	3551111	
36 0 19 12	6X17AC	07 126 212	6X18AB	3373267	
36 0 19 28	6X17AC	07 126 312	6X18AB	3373267	

Spare or unequipped OEs - unavailable

This report shows the OE-to-LEN mappings for OEs that are not assigned to working DNs but which are mapped to unavailable LENs in the DMS (test reference lines or reserved circuits).

Figure 3-13 shows a segment from this report.

Figure 3-13xxx

Spare or unequipped OEs - unavailable

Spare or Unequipped OEs - Unavailable			Page #
Office Name (H#)			Date

OE	LEN	Card Code	

00 000 000	00 0 00 00	6X17AC	
01 220 200	08 1 11 00	6X20AA	
01 423 115	15 1 06 31	6X71AB	
04 207 315	21 1 17 31	6X71AB	
04 322 200	20 1 11 00	6X20AA	
05 125 215	29 0 19 15	6X71AB	
05 204 015	28 0 16 15	6X71AB	
05 204 115	28 0 16 31	6X71AB	
06 423 315	32 1 19 31	6X71AB	
07 025 300	35 0 11 16	6X20AA	

Spare or unequipped OEs - available

This report shows the LENs in the DMS which may be used for relocating service to resolve circuit pack conflicts noted in the "Circuit Pack Conflicts" reports (both ESS Impacting and DMS Impacting).

Figure 3-14 shows a segment from this report.

Figure 3-14
Spare or unequipped OEs - available

Spare or Unequipped OEs - Available			Page #
Office Name (H#)			Date

OE	LEN	Card Code	

06 524 202	32 0 03 02	6X17AC	
06 527 302	33 1 03 18	6X17AC	
07 000 002	33 1 04 02	6X17AC	
07 000 102	33 1 04 18	6X17AC	
07 000 204	33 1 05 04	6X17AC	
07 000 207	33 1 05 07	6X17AC	
07 000 314	33 1 05 30	6X17AC	
07 001 309	35 0 01 25	6X17AC	
07 002 110	33 1 08 26	6X17AC	
07 002 205	33 1 09 05	6X17AC	
07 003 004	35 0 04 04	6X17AC	
07 003 105	35 0 04 21	6X17AC	
07 004 002	33 1 12 02	6X17AC	
07 106 206	36 0 17 06	6X17AC	
07 107 301	37 1 13 17	6X17AC	
07 120 004	34 0 02 04	6X17AC	
07 121 100	35 0 18 16	6X17AC	
07 121 203	35 0 19 03	6X17AC	
07 122 004	34 0 06 04	6X17AC	
07 125 011	35 1 06 11	6X17AC	
07 125 206	35 1 07 06	6X17AC	
07 127 000	37 1 14 00	6X17AC	
07 127 205	37 1 15 05	6X17AC	
07 127 314	37 1 15 30	6X17AC	

OEs with multiple DNs assigned

This report lists the OEs and LENSs to which more than one DN are assigned.

Figure 3-15 shows a segment from this report.

Figure 3-15xxx
OEs with multiple DNs assigned

OEs With Multiple DNs Assigned						Page #
Office Name (H#)						Date
OE	DN	LCC	Start Type	LEN	Card Code	
00 007 001	3511154	2MR	Loop	01 1 08 01	6X17AC	
00 007 001	3511491	2MR	Loop	01 1 08 01	6X17AC	
00 023 302	3321924	2MR	Loop	01 1 03 18	6X17AC	
00 023 302	3325909	2MR	Loop	01 1 03 18	6X17AC	
00 402 305	3510789	2MR	Loop	11 0 13 21	6X17AC	
00 402 305	3517585	2MR	Loop	11 0 13 21	6X17AC	
00 503 305	3513564	2MR	Loop	13 0 05 21	6X17AC	
00 503 305	3518422	2MR	Loop	13 0 05 21	6X17AC	
01 100 012	3513190	2MR	Loop	06 0 08 12	6X17AC	
01 100 012	3518510	2MR	Loop	06 0 08 12	6X17AC	
01 500 107	3514376	2MR	Loop	14 1 00 23	6X17AC	
01 500 107	3515211	2MR	Loop	14 1 00 23	6X17AC	
02 121 011	3371830	2MR	Loop	05 0 02 11	6X17AC	
02 121 011	3376419	2MR	Loop	05 0 02 11	6X17AC	
02 122 008	3370494	2MR	Loop	03 1 10 08	6X17AC	
02 122 008	3377898	2MR	Loop	03 1 10 08	6X17AC	
02 221 100	3370744	2MR	Loop	05 0 18 16	6X17AC	
02 221 100	3511688	2MR	Loop	05 0 18 16	6X17AC	
02 224 202	3322968	2MR	Loop	06 0 15 02	6X17AC	
02 224 202	3519277	2MR	Loop	06 0 15 02	6X17AC	
02 307 101	3325537	2MR	Loop	08 0 08 17	6X17AC	
02 307 101	3379300	2MR	Loop	08 0 08 17	6X17AC	
02 405 305	3370593	2MR	Loop	18 1 05 21	6X17AC	
02 405 305	3513916	2MR	Loop	18 1 05 21	6X17AC	

Allowed circuit pack conflicts

If an LNINV table exists for the new DMS office, this report shows the circuit pack conflicts that occurred during the OE-to-LEN mapping but which are allowable, based on a customer-provided circuit pack substitution list. Even though the circuit pack specified by the customer for a given OE is different than the circuit pack called for by the LNINV table (if available) for the associated LEN, the discrepancy is not considered a grooming issue, since the same service can be supported by the substitute circuit pack.

Note: This report is not produced if no LNINV table exists for the new DMS office.

Figure 3-16 shows a segment from this report.

Figure 3-16xxx
Allowed circuit pack conflicts

Allowed Circuit Pack Conflicts				Page #
Office Name (H#)				Date
DMS (LNINV)			ESS	
LEN	Circuit Pack	OE	Pred. Circuit Pack	DN
00 0 00 10	6X19AA	00 000 010	6X18AB	3550567
00 0 01 12	6X19AA	00 000 212	6X18AB	3515903
00 0 01 26	6X19AA	00 000 310	6X18AB	3552432
00 0 02 20	6X18AA	00 020 104	6X17AC	3379104
00 0 02 31	6X19AA	00 020 115	6X18AB	3550628
00 0 03 12	6X18AB	00 020 212	6X17AC	3322585
00 0 03 20	6X18AB	00 020 304	6X17AC	3379969
00 0 03 31	6X19AA	00 020 315	6X18AB	3558602
00 0 04 31	6X19AA	00 002 115	6X18AB	3550650
00 0 05 12	6X18AB	00 002 212	6X17AC	3510817
00 0 05 28	6X18AB	00 002 312	6X17AC	3376458
00 0 05 31	6X19AA	00 002 315	6X18AB	3535762
00 0 06 30	6X19AA	00 022 114	6X18AB	3539727
00 0 07 12	6X18AB	00 022 212	6X17AC	3532281
00 0 07 20	6X18AB	00 022 304	6X17AC	3379861
00 0 07 28	6X18AB	00 022 312	6X17AC	3533111
00 0 07 31	6X18AB	00 022 315	6X18AB	3553568
00 0 08 30	6X19AA	00 004 114	6X18AB	3553697
01 1 01 28	6X19AA	00 003 312	6X18AB	3378962
01 1 02 04	6X18AB	00 023 004	6X17AC	3379808
01 1 02 31	6X19AA	00 023 115	6X18AB	3552618
01 1 04 31	6X19AA	00 005 115	6X18AB	3553530
01 1 05 12	6X19AA	00 005 212	6X17AC	3371731

Circuit pack usage summary

This report shows the number of occurrences for each circuit pack found in each LCE, LCM, and LSG of the DMS office. The report provides totals for each LCM and also list the number of spare LENS in each LSG.

Figure 3-17 shows a segment from this report.

Figure 3-17xxx
Circuit pack usage summary

Circuit Pack Usage Summary										Page #
Office Name (H#)										Date
			6	6	6	6	6	6	6	
			X	X	X	X	X	X	X	
			1	1	1	2	2	7	9	
			7	8	9	0	1	1	9	
			A	A	A	A	A	A	A	
LCE	LCM	LSG	C	B	A	A	C	B	A	Spare LENS
00	0	00	24	4	0	0	0	0	0	4
00	0	01	23	3	0	0	0	0	0	6
00	0	02	27	0	0	0	0	0	0	5
00	0	03	24	4	0	0	0	0	0	4
00	0	04	23	3	0	0	0	0	0	6
00	0	05	27	0	0	0	0	0	0	5
00	0	18	27	0	0	0	0	0	0	5
00	0	19	24	4	0	0	0	0	0	4
LCM	0	Totals	509	50	0	0	0	0	0	81
00	1	00	24	4	0	0	0	0	0	4
00	1	01	23	3	0	0	0	0	0	6
00	1	02	27	0	0	0	0	0	0	5
00	1	17	23	3	0	0	0	0	0	6
00	1	18	27	0	0	0	0	0	0	5
00	1	19	24	4	0	0	0	0	0	4
LCM	1	Totals	493	57	0	0	0	0	0	89

List of terms

ABBT

Automatic Board-to-Board Testing; DMS-100 software package used to check the wiring between each line card in the new DMS-100 and its cross-connections to the existing switch at the main distributing frame (MDF); also called board-to-board testing.

BOC

Bell Operating Company.

BPI

Bits per inch; a measurement that indicates the density of data on magnetic tape.

CCS

Cutover Conversion Service; Northern Telecom department that provides complete data analysis and data processing services associated with central office switching system conversions.

Central office

A switching office arranged for terminating subscriber lines and provided with switching equipment and trunks for establishing connections to and from other switching offices.

Centrex

Centralized PBX; a service that provides a business telephone subscriber with Direct Inward Dialing to extensions on the same system and Direct Outward Dialing from all extensions. Centrex switching equipment is normally located at the central office, but may be located on the operating company client's premises.

Chart class column

ESS data element used for screening calls with respect to class of service.

Chart column expansion data

The Line Class Code (LCC), originating major, and terminating major values associated with a given chart class column number; defines the class of service for a subscriber line.

Control group

An alphanumeric value, usually the first character of the ESS Operating Equipment (OE) number; indicates whether the line is from a remote switch, or RSC, or from the host (central) office.

Conversion

The translating of line assignments and line feature data from an existing on-line, central office switch for loading into a replacement central office switch (e.g., ESS-to-DMS-100 conversion).

COSMIC

A modular distributing frame that uses software programs and the short jumper concept to cross-connect the line equipment to the subscriber cable pair.

COSMOS

Computer System for Main Frame Operations; database used for storing central office switch subscriber line assignment, line feature, and office equipment (hardware) data.

COT

Central Office Terminal.

CRIS

Customer Records Information System; central office switch database used primarily for maintaining subscriber billing information.

Crossbar

An electromechanical switching machine utilizing a relay mechanism with horizontal and vertical input lines (usually 10 by 20), using a contact matrix to connect any vertical to any horizontal.

Cutover

Process by which telephone switching service is removed from one switching system and transferred to another; occurs shortly after the conversion process is successfully completed.

Dial transfer

Process by which line assignment and line feature database information from one switch is updated to reflect its reassignment in another central office switch.

Dialup

Device consisting of telecommunications hardware and software that enables data to be sent and received over telephone lines between two or more computer systems.

Distributing frame

A structure with terminations for connecting permanent wiring in such a manner that interconnections may be readily achieved by means of cross-connecting wires.

DMS

Digital Multiplexing System; a Northern Telecom family of digital public switching equipment.

DN

Directory Number.

DS1

The 8-bit, 24-channel, 1.544 Mb/s digital signalling format as used in the DMS-100 family.

DSX

Digital Span Cross-connect

Dumptab

DMS-100 software utility used for dumping, or writing, DMS-100 line assignment and line feature data to 9-track magnetic tape.

ESS

Electronic Switching System; an AT&T family of digital public switching equipment.

Global option

A characteristic of subscriber line service that is implicitly assigned through the class of service associated with the line.

Grooming

The process by which either the existing, on-line central office switch, or the replacement switch (or both) is prepared for a cutover in a half-tapping application; grooming helps assure that the transfer of line service from one switch to another is performed according to particular engineering and provisioning rules related to line service spread, traffic, and realtime issues.

Ground start

A method of signalling between two machines where one machine grounds one side of the line and the other machine detects the presence of the ground.

Half-tap

A switch installation configuration by which customer lines appear on both the existing and the replacement central office switching systems; at cutover, the lines to the old switch are disconnected and the replacement switch then assumes the central office switching duties.

IBN

Integrated Business Network; a special DMS-business services package that uses the data handling capabilities of a DMS-100 family office to provide a centralized telephone exchange service; many optional features are available.

In-service date

The date when the replacement central office switch assumes the switching functions for the office.

K-date

The date on which Northern Telecom completes all installation-related activities and turns the DMS switch over to the operating company.

LATAname

Local Area Transport Area; indicates the region served by a central office switching facility.

LCC

Line Class Code; code used to specify the class of service associated with a given subscriber line.

LCE

Line Concentrating Equipment

LCM

Line Concentrator Module

LEN

Line Equipment Number; a seven-digit function reference used to identify line circuits in the DMS-100.

Line attribute index

Index number to the line attribute (LINEATTR) index table in the DMS-100; points to a collection of data elements which define a particular class of service for a subscriber line.

Line feature

A characteristic, or capability that can be assigned either in hardware or through software data tables to a subscriber's telephone line to provide any of the available telephone switching services (e.g., conference calling, call waiting, call forwarding, etc.).

Loop start

The usual method of signalling an off-hook or line seizure, where one end closes the loop and the resulting current flow is detected by the switch at the other end.

LSG

Line SubGroup; also called a drawer; contains line cards.

LTG

Line Treatment Group.

MADN

Multiple Appearance Directory Number.

MDC

Meridian Digital Centrex; DMS-100 central office switch-based PBX services .

MDF

Main Distributing Frame; a frame containing terminal blocks where cables from outside plant and office equipment are terminated. Outside plant equipment is terminated on vertical rows of blocks and office equipment on horizontal rows. Cross-connection flexibility and organization is provided by jumper pairs between horizontal and vertical terminal blocks.

NXX

The telephone switching exchange designation; the three digits of the telephone number following the area code and preceding the last four digits of the DN.

No-test trunk

ESS resident metallic test access used during board-to-board testing between the new DMS-100 switch and the existing, on-line ESS switch.

ODA

Office Data Assembler; data format used to extract line assignment and line feature data from #2ESS and #3ESS switches.

OE

Operating Equipment; identifies the subscriber line termination at the ESS central office switch.

Operating company

The owner/operator of central office switching equipment.

Originating major class

ESS data element (part of the chart class column expansion data) that specifies the call processing treatment for originating calls.

PABX or PBX

Private (automatic) branch telephone exchange system (either stand-alone or central office-based) providing telephone switching in an office or building.

PIC

Primary InterLATA Carrier.

POTS

Plain Old Telephone Service.

RCR

Recent Change Report; a type of record created in the COSMOS database to remove service for a subscriber line.

Recent change

A record that specifies a change of service (addition, deletion, modification, etc.) for a given subscriber line.

RSC

Remote Switching Center; provides facilities for interfacing with a large number of analog lines and/or digital trunking at a remote location.

SCC

Switching Control Center.

Servord

Service Order (DMS-100).

Sitename

The designation for the location of the switching equipment.

SLC96

Subscriber Line Concentrator-96.

Step switch

An electromechanical telephone switching system in which the switches are controlled directly by digits dialed by the calling party.

Stored program controlled switch (SPC)

A telephone switching system in which switching and call processing functions are implemented through software contained (stored) in switch memory.

Tabdump

Command file that contains a series of DMS-100 DUMPTAB table dumping commands.

TDA

Translation Data Assembler; data format used in the extraction of line assignment and line feature data from #1AESS and #1ESS AT&T switches.

Terminating major

ESS data element (part of the chart class column expansion data) that specifies the call processing treatment for terminating calls.

TMART

Transfer Master Record Tape.

TN

Telephone Number.

TRC

Transfer Recent Change; a type of record created in the COSMOS database to modify service for a subscriber line.

Trouble ticket

A document that details the board-to-board test failure record for a given line.

USOC

Universal Service Order Code.

DMS-100 Family

Cutover Conversion Services

Customer Grooming Method of Procedure

© 1989, 1990, 1991, 1992 Northern Telecom
All rights reserved.

Information is subject to change without notice. Northern Telecom reserves the right to make changes in design or components as progress in engineering and manufacturing may warrant.

DMS, DMS SuperNode, MAP, Digitone and NT are trademarks of Northern Telecom. 1AESS, 1ESS, 2ESS, 2BESS, 3ESS, ESS, SLC96 and TouchTone are trademarks of AT&T.

Publication number: 297-0301-301
Product release: BCS27 and up unless reissued
Document release: Standard 02.05
Date: July 1992

Printed in Canada and printed in the United States of America.

